



MARWIN VALVE

3170 Wasson Road • Cincinnati, OH 45209 USA
Phone 513-533-5600 • Fax 513-871-0105
marwin@richardsind.com • www.marwinvalve.com

I & M MS10000 Series

Installation & Maintenance Instructions for Marwin MS10000 Series Three Piece Ball Valves

Warning: Marwin Valve Ball Valves must only be used, installed and repaired in accordance with these Installation & Maintenance Instructions. Observe all applicable public and company codes and regulations. In the event of leakage or other malfunction, call a qualified service person; continued operation may cause system failure or a general hazard.

Please read these instructions carefully!

Your Marwin Valve product will provide you with long, trouble-free service if it is correctly installed and maintained. Spending a few minutes now reading these instructions can save hours of trouble and downtime later. When making repairs, use only genuine Marwin Valve parts, available for immediate shipment from the factory.

Scope

This manual is intended as a guide to assist customers in the storage, installation, and maintenance of Marwin MS10000 Series ball valves. Subsequent additions or special instructions will be provided for special ball valves, critical service, or customer requirements.

Applicability



This manual is applicable to the MS10000 Series Marwin ball valves.

Caution

To help prevent injury to personnel or damage to equipment, please read this section completely before performing any operations.

1. Valve pressure ratings are based on many variables, including valve series and size, as well as body, seat and bolt material. Verify that application does not exceed the pressure or temperature rating on the nameplate.
2. **ALWAYS** depressurize the line with the valve in the **OPEN** position before disassembly.
3. Wear protective equipment and take appropriate precautions to safeguard against injury caused by the discharge

of trapped fluids.

4. Use only Marwin recommended spare parts for maintenance.
5. To ensure safety and maintain warranty, never modify valve in any way without prior approval from Marwin.

Storage

A petroleum based oil (silicone free) is used as lubrication on all internal surfaces. This may be removed with a solvent if found objectionable. All valves are adequately packed in a strong cardboard case in such a way as to avoid any possible damage during transport and storage.

CAUTION: If ball valves are not destined for immediate use, the following precautions should be taken:

1. If possible, leave the ball valves in their packing cases during the period of storage.
2. Ball valves must remain in open position during this time.
3. In order to prevent damage, protective plastic covers on valve ends should not be removed until immediately prior to installation.
4. It is advisable to store the valves in waterproof conditions. Ball valves should be protected to safeguard against humidity, moisture, dust, dirt, sand, mud, salt spray and seawater.
5. All valves complete with actuators are to be stored in dry conditions.
6. Valves to be stored for a long period of time should be checked by the quality control personnel every six months, every three months when valves are automated.

Maintenance During Storage Period

- Internal surface should be inspected to check for dust or other foreign objects.
- Rust or dust must be removed by cleaning with proper solvent.
- After cleaning, ball valves must be lubricated with an adequate lubricant.
- Ball valves should be operated for at least two complete cycles before installing or returning to storage.

Installation

The ball valves may be installed in any position using Standard Pipe Fitting Practice.

CAUTION: Before installation of the valve:

1. Pipe must be free of tension both during and after installation.
2. Pipe must be flushed to clean dirt, welding residues, etc. which would damage ball or seats.
3. The valve should be kept in OPEN POSITION during installation and protective plastic covers must be removed only at the moment of installation.
4. Before shipment, the ball is lubricated with a petroleum based oil. This can be easily removed with an application compatible solvent if required.
5. If the valve was specified to be tested per ASTM 16.34, there may be some trapped water between the ball and the body cavity. This can be removed by partially opening the valve, thereby exposing the cavity to the through port of the ball.
6. Special care should always be taken when installing automated ball valves that the ball is in the proper position.

Installation of Threaded Ends

1. Unless otherwise specified, pipe threads are per ANSI B1.20.1 and require applicable pipe sealant.
2. Install valve using standard piping practices.
3. When tightening valve, apply wrench to the end cap nearest the pipe being worked on.

Extended Weld End Valves

The standard weld end connections (female socket and butt weld versions) are extended ends (ANSI 600# face to face) with integral cooling fins to dissipate the heat associated with the welding process. This allows most valves to be welded in-line without disassembly, given the following guidelines.

1. Valve must be in the full open position.
2. Limit continuous weld time to 1 minute.
3. Direct moving air across finned area, or wrap extended end with wet cloth.
4. Body bolts are checked for torque after complete cooling of weld area per re-assembly section of this procedure.

Installation of Flanged-Ends

1. Verify valve is in the full open position.
2. Use the appropriate size bolt and heavy hex nut (not included) as recommended for flange size and class.
3. Flange connection requires gasket (not included).
4. Follow gasket manufacturer's recommended practice for tightening flange bolts.

Manual Operation

1. Open and close the valve by turning the handle 1/4 turn (90°).
 2. Valve is in open position when handle is in line with the pipe.
 3. Valve is in closed position when the handle is perpendicular to the pipe.
-

Maintenance

Before starting maintenance, please read information contained in the **Caution Section** of the manual.

1. Open and close the ball valve at least once to release the pressure completely from valve body.
2. Ball valves, if correctly used, normally do not need any internal lubrication and maintenance. However, when necessary, ball or seats can be replaced by qualified personnel following the instructions of this manual.
3. For further information about recommended SPARE PARTS LIST, please check drawing, catalog, or contact the factory.

Valve Disassembly

The MS10000 Series valves seat require special care when trying to repair in-line. If possible, the valve should be removed intact from the pipeline before disassembly (step 4 can be then be omitted). If ends have been welded in place and not removable, follow these steps (see warnings on page 1):

1. Operate valve to full open position. (The ball will extend into end caps in the closed position).
2. Remove all body bolts.
3. Separate ends (up to 1/4" per side), to allow body to clear end cap lips. (Take care not to damage body seal contact seal surfaces on end caps).
4. Remove body center section and valve seats from end caps.
5. Close valve and remove ball (protect ball).
6. Remove handle for manual valves, or bracket and coupler if automated.
7. Remove body gaskets / o-rings and emergency gaskets / o-rings from body. Some gasket materials may require "picking" from groove, be careful not to scratch metal mating surface.
 - a. Remove gland flange nuts, flange and metal packing gland. Push the stem down through the body and remove stem collars and thrust washer, then pull stem out of top.
8. Now that the packing ID has been exposed, carefully pry out old packing and thrust washer(s).

Inspection and Replacement

With the valve completely disassembled, clean and examine all components:

1. The surface of the ball should be free from any defect. If any are found, the ball should be replaced. Using a defective ball will be extremely detrimental to valve performance.
2. Seats: Replacement of seats is recommended if they have been damaged or the coating has been worn through.
3. Seat seals and body seals: Should be discarded and replaced.
4. Remaining components of the valves: After cleaning, carefully examine for wear, corrosion, and mechanical damage. Replace all defective parts.
5. Clean inside of body and stem housing. Light grease, compatible with line fluid, can be used on ball, seals and stem surfaces.

NOTE: A spare parts list is available for this valve. See Exploded View on page four for identification. Please specify valve number to ensure proper parts are ordered.

Assembly

1. Make sure valve components are clean and free of burrs and imperfections on sealing surfaces.
2. Insert stem into flow passage of valve body and into stem bore.
3. Place thrust washer onto stem and up into body.
4. Place stem collars in groove on stem, and push stem up, so that collars are contained in body counter bore.
5. Rotate stem to full closed position and insert ball, making sure slot is engaged and ball is not bound to valve body. Slight tapping with resilient material is okay, but ball should not be forced into place.
6. While holding stem from bottom, place packing ring(s) over stem and down into bore (1 braided, 2 compressed graphite, 1 braided), and packing gland.
7. Carefully rotate stem to the full open position. Valve handle (with soft pad) or other protected extension can be placed thru ball opening to prevent stem from turning.
8. Place packing flange onto top of packing gland. Install flange nuts and tighten (in alternating pattern).
9. Place body seal and emergency seal into grooves on downstream side of body.
10. With one end cap in vise or still welded in place, place seat and seat gasket into cavity of downstream end cap.
11. Rotate body to properly align bolt holes and stem orientation to end cap.
12. Using anti-seize compound, install body bolts and hand tighten.
13. Place seals into body grooves of upstream side. Place seat and Bellville washer into seat pocket of upstream end cap.
14. Repeat steps 11 and 12.
15. Lubricate ball with a system compatible compound, then cycle ball fully at least three times. With the valve in the closed position, using an alternating and opposing pattern, torque the bolts for the downstream end cap to recommended torques per attached bolt torque chart. Tightening each bolt no more than 1/8th turn before alternating.
16. Repeat step 15 for upstream end cap then again cycle valve fully three times.
17. Verify handle orientation, replace handle, handle coupler nut on manual valve or replace coupler and bracket on automated valves.

Troubleshooting

Stem Leak

1. Rotate packing flange nuts in 1/4 turn increments.
 - a. Continuous leakage requires replacement of all stem seals.
 - i. Braided, Anti-extrusion rings (above and below)
 - ii. Packing (middle rings)
2. See Disassembly and Re-Assembly Sections of this document.

Body External Leak

1. Torque the body bolts to the proper value for the bolt size and material. (See the chart below and tightening instructions.)
2. Note: Stainless steel bolts are more susceptible to stretching and should be replaced if they have possibly been over-torqued.
3. Continuous leakage requires replacement of two seals per side.
 - a. Body seal
 - b. Secondary body seal
4. See Disassembly and Re-Assembly Sections of manual.
 - a. Verify that there are no piping stresses preventing bolt torques from loading body seals adequately.
 - b. Optional elastomer body and/or emergency o-ring seals may be available depending on specific service media and conditions.

Seat (in-line) Leak

1. Remove body bolts and slide out center section.
2. Inspect seats and ball for evidence of excess wear.
3. If downstream seats have been worn, exchange upstream seat for downstream.
4. The ball should also be reversed if the seats are being reversed. Continuous leakage requires replacement of all four seat components.
 - a. Seats (2)
 - b. Ball
 - c. Seat gasket
 - d. Bellville washer

Bolt Torque Value Table

MS10000 Series	Bolt Information		Bolt Material with Torque (in./lbs.)	
	Bolt Size	Bolt Qty. (per end cap)	B7 Steel	B8 Stainless Steel
1/4" - 1/2" F	3/8	6	300	170
3/4" F	1/2	6	650	420
1" F	9/16	6	800	650
1 1/4" - 1 1/2" F	9/16	8	800	650
2" F	9/16	10	800	650

Exploded View

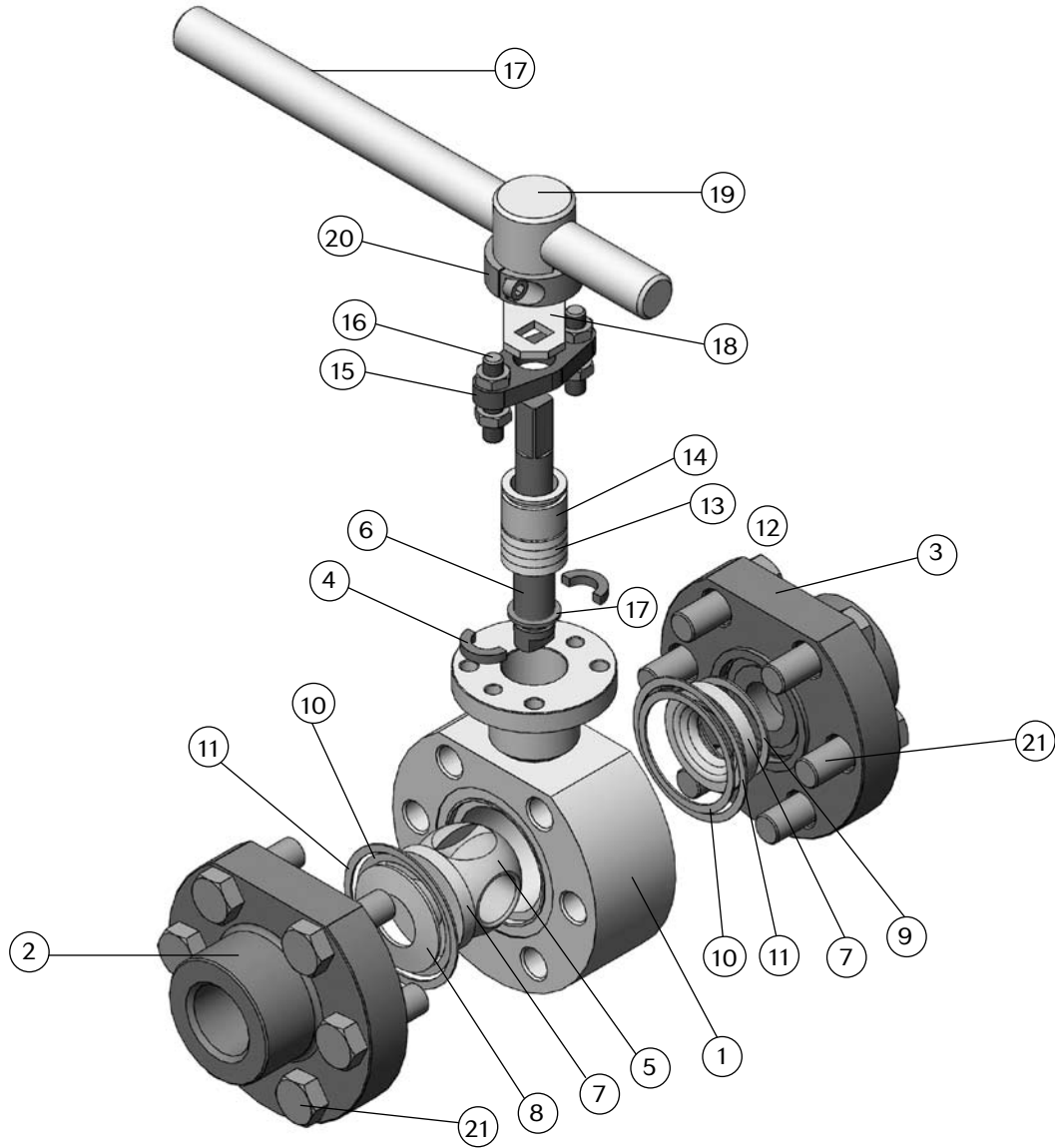

Item	Description	Qty.	SST Material	CS Material	Item	Description	Qty.	SST Material	CS Material
1	Body/Bonnet	1	A479-316L SS	SA-A106 CS	12*	Thrust Washer	1	Carbon	Carbon
2	End Cap Upstream	1	A479-316L SS	SA-A106 CS	13*	Packing	3	Grafoil	Grafoil
3	End Cap Downstream	1	A479-316L SS	SA-A106 CS	14	Packing Gland	1	316 SS	316 SS
4	Stem Collar	1	A479-316L SS	A479-316L SS	15	Packing Flange	1	SST	SST
5	Ball	1	316SS/Marwear	316SS/Marwear	16	Packing Stud/Nut	2	SST	SST
6	Valve Stem	1	17-4 SS	17-4 SS	17	Handle	1	SST	SST
7*	Seat	2	316SS/Marwear	316SS/Marwear	18	Stop	1	SST	SST
8	Seat Belleville	1	Inconel	Inconel	19	Handle Tee	1	SST	SST
9*	Seat Gasket	1	Graphite	Graphite	20	Coupler Collar	1	SST	SST
10*	Body Seal	2	Graphite	Graphite	21	Body Bolts	per	A194-B8-SST	A194-B7-CS
11*	Secondary Body Gasket	2	Graphite	Graphite					

* Recommended Repair Parts: Item 7 (2), Item 9 (1), Item 10 (2), Item 11 (2), Item 12 (1), Item 13 (1)