



MARWIN VALVE

3170 Wasson Road • Cincinnati, OH 45209 USA  
Phone 513-533-5600 • Fax 513-871-0105  
marwin@richardsind.com • www.marwinvalve.com

## I & M KF8900 Series

### Installation & Maintenance Instructions for Marwin KF8900 Series Three Piece Ball Valves

Warning: Marwin Valve ball valves must only be used, installed and repaired in accordance with these Installation & Maintenance Instructions. Observe all applicable public and company codes and regulations. In the event of leakage or other malfunction, call a qualified service person; continued operation may cause system failure or a general hazard.

### Please read these instructions carefully!

Your Marwin Valve product will provide you with long, trouble-free service if it is correctly installed and maintained. Spending a few minutes now reading these instructions can save hours of trouble and downtime later. When making repairs, use only genuine Marwin Valve parts, available for immediate shipment from the factory.

### Scope

This manual is intended as a guide to assist customers in the storage, installation, and maintenance of Marwin KF8900 Series ball valves. Subsequent additions or special instructions will be provided for special valves, critical service or customer requirements.

### Applicability

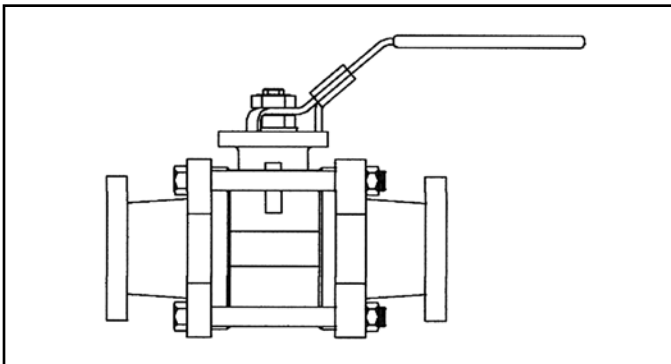

This manual is applicable to the KF8900 Series Marwin three piece ball valves.

### Caution

To help prevent injury to personnel or damage to equipment, please read this section completely before performing any operations.

1. Valve pressure ratings are based on many variables, including valve series and size, as well as body, seat and bolt material. Verify that application

does not exceed the pressure or temperature rating on the nameplate.

2. **Always** depressurize the line with the valve in the **open** position before disassembly. Cycle valve in depressurized line before removing valve.
3. Wear protective equipment and take appropriate precautions to safeguard against injury caused by the discharge of trapped fluids.
4. Use only Marwin recommended spare parts for maintenance.
5. To ensure safety and maintain warranty, never modify valve in any way without prior approval from Marwin.

### Storage

No internal lubricant is used on these valves. An FDA H-1 food grade incidental contact lubricant may be used on the threads of the body-end cap bolts. All valves are adequately packed in a strong cardboard case in such a way as to avoid any possible damage during transport and storage.

**Caution: if ball valves are not destined for immediate use, the following precautions should be taken:**

1. If possible, leave the ball valves in their packing cases during the period of storage.
2. Ball valves must remain in open position during this time.
3. In order to prevent damage, protective plastic covers on valve ends should not be removed until immediately prior to installation.
4. It is advisable to store the valves in waterproof conditions. Ball valves should be protected to safeguard against humidity, moisture, dust, dirt sand, mud, salt spray and seawater.
5. All valves complete with actuators are to be stored in dry conditions.
6. Valves to be stored for a long period of time should be checked by the quality control personnel every six months; every three months when valves are automated.

### Maintenance During Storage Period

- Internal surface should be inspected to check for dust or other foreign objects.
- Rust or dust must be removed by cleaning with proper solvent.
- After cleaning, ball valves must be lubricated with an adequate lubricant.
- Ball valves should be operated for at least two complete cycles before installing or returning to storage.

---

## Installation

---

The ball valves may be installed in any position using standard pipe fitting practices.

### Caution: Before installation of the valve:

1. Pipe must be free of tension both during and after installation.
2. Pipe must be flushed to clean dirt, welding residues, etc. which would damage ball or seats.
3. The valve should be kept in OPEN POSITION during installation and protective plastic covers must be removed only at the moment of installation.
4. Before shipment, the ball is lubricated with a pure Vaseline oil. This can be easily removed with an application compatible solvent if required.
5. If the valve was specified to be tested per ASME 16.34, there may be some trapped water between the ball and the body cavity. This can be removed by partially opening the valve, thereby exposing the cavity to the through port of the ball.
6. Special care should always be taken when installing automated ball valves that the ball is in the proper position.

### ■ Installation of Quick Disconnect Ends

7. Be sure only specified gasket and clamp are used.
8. Be sure gasket is properly seated before tightening clamp.

---

## Manual Operation

---

1. Open and close the valve by turning the handle one-quarter turn (90°).
2. Valve is in open position when handle is in line with the pipe.
3. Valve is in closed position when the handle is perpendicular to the pipe.

---

## Maintenance

---

Before starting maintenance, please read information contained in the **Caution Section** of the manual.

1. Open and close the ball valve at least once to release the pressure completely from valve body.
2. Ball valves, if correctly used, normally do not need any internal lubrication and maintenance. However, when necessary, ball or seats can be replaced by qualified personnel following the instructions of this manual.
3. For further information, please refer to **SPARE PARTS LIST**.

---

## Valve Disassembly

---

### A. To inspect and/or Replace Body Seals, Seats, Packing & Ball

*Reference cross section for part identification*

1. Valve must be in the open position.
2. Remove one body bolt (2) opposite hinge point and loosen all others. This will allow valve to swing out.
3. Close the ball and remove seats (4), ball (5), and body seals (3). Be careful not to damage the ball.
4. Remove the handle nut (13), handle (11), gland nut (10), gland (9), and stem packing (8).
5. Push the stem (6) into the body (17). Remove thrust washer (7) from stem.

### B. Inspection and Replacement

With the valve completely disassembled, clean and examine all components.

1. The surface of the ball should be free from any defect. If any are found, the ball should be replaced. Using a defective ball will be extremely detrimental to valve performance.
2. Seats. Replacement of seats is recommended.
3. Stem seals and body seals. Should be discarded and replaced.
4. Remaining components of the valve. After cleaning, carefully examine for wear, corrosion and mechanical damage. Replace all defective parts.
5. Clean inside of body and stem housing. Light grease, compatible with line fluid, can be used on ball, seals and stem surface.

**Note: A spare parts list is available for this valve. Please refer to explosion view below for identification. Please specify specific valve number to ensure proper parts are ordered. Marwin Valve does not take responsibility for incorrectly ordered spare parts.**

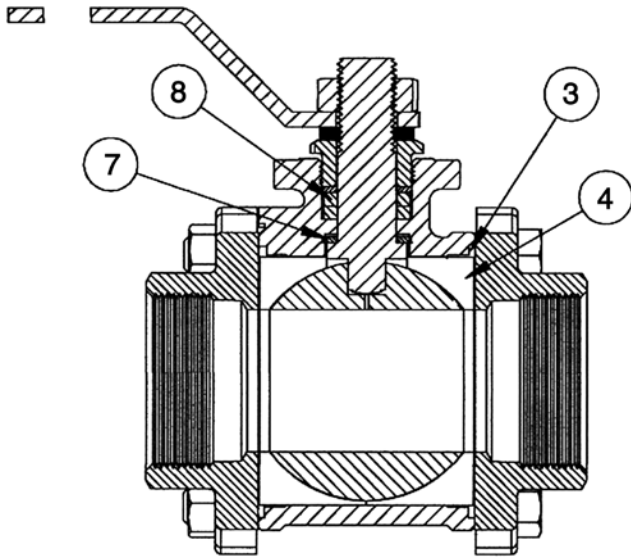

### Spare Parts List

Item #	Quantity	Part Name
3	2	Body Seal
4	2	Seat
7	1	Thrust Washer
8	1	Stem Packing

## Re-Assembly

### A. Stem

1. Replace thrust washer (7) then insert the stem (6) from inside the body (17).
2. Install stem packing (8), gland nut (10) and tighten until snug, then one-half turn. Do not overtighten! To avoid rotation of stem, insert the handle and ball.
3. Install handle (11) and handle nut (13) then tighten.

### B. Ball, Seats and Seals

1. Place the stem in closed position and insert the ball, aligning groove in ball with bottom of stem.
2. Position the ball in the open position then insert the seats and body seals.
3. Insert the centerpiece between the end caps, re-install removed bolts and tighten all bolts and nuts by hand.
4. Tighten nuts to recommended torque values using an alternating/opposing pattern with no more than 1/4 turn on each nut before alternating.

## Testing

1. After completing the reassembly, check that valve operates smoothly by opening and closing valve several times.
2. If entire valve was removed from line and if facilities area available, test the ball valve to appropriate specifications.

## Troubleshooting

### A. Stem Leakage

1. You can eliminate leakage in the stem area by increasing the torque on the gland nut (10) in one-quarter turn increments. If leakage persists, replace stem packing (8).

### B. Body Seal Leakage

1. Check the torque of the body bolts (10) according to Torque Table. Replace body seals (3) if leakage persists.

### C. In Line or Seat Leakage

1. Check to be sure valve is in fully closed position. If leakage persists, the valve must be disassembled and damaged parts replaced.

## Body Bolt Torque Valve Table

Valve Size	Body Bolt Torque (in/lbs)
1/4"	60
3/8"	60
1/2"	150
3/4"	150
1"	150
1-1/4"	290
1-1/2"	290
2"	290
2-1/2"	325
3"	400
4"	400

## Exploded View

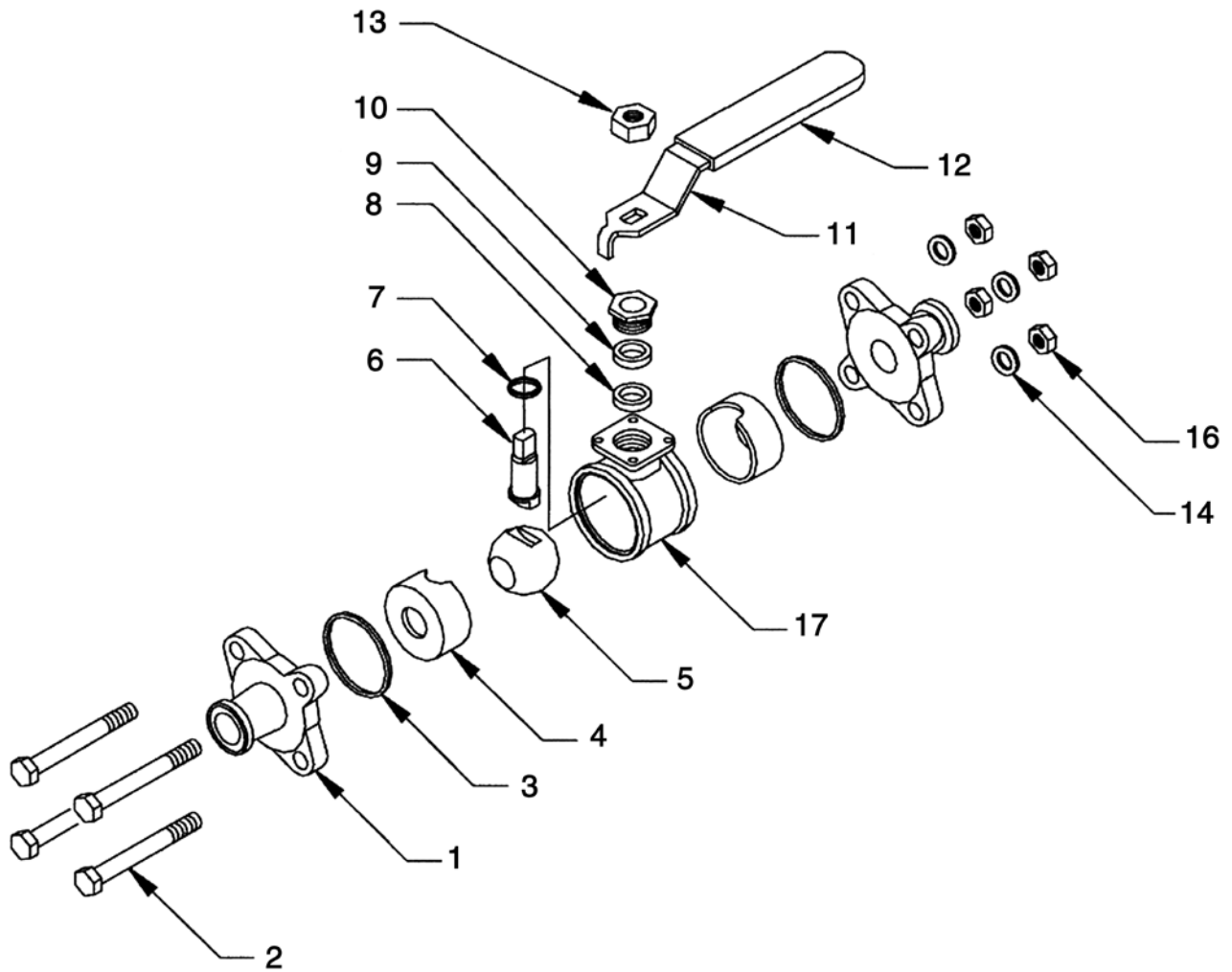

Item #	Quantity	Part Name	Item #	Quantity	Part Name
1	2	End Caps	9	1	Gland
2	4	Body Bolts	10	1	Gland Nut
3	2	Body Gasket	11	1	Handle
4	2	Seat Rings	12	1	Handle Cover
5	1	Ball	13	1	Handle Nut
6	1	Stem	14	4	Washer
7	1	Thrust Washer	16	4	Nut
8	2	Stem Packing	17	1	Body