



MARWIN VALVE

3170 Wasson Road • Cincinnati, OH 45209 USA  
Phone 513-533-5600 • Fax 513-871-0105  
marwin@richardsind.com • www.marwinvalve.com

## I & M ER Series

*Installation & Maintenance Instructions for  
Marwin ER Series Electric Actuators*

**Warning:** Marwin Valve Ball Valves and Actuators must only be used, installed and repaired in accordance with these Installation & Maintenance Instructions. Observe all applicable public and company codes and regulations. In the event of leakage or other malfunction, call a qualified service person; continued operation may cause system failure or a general hazard.

### Please read these instructions carefully!

Your Marwin Valve product will provide you with long, trouble-free service if it is correctly installed and maintained. Spending a few minutes now reading these instructions can save hours of trouble and downtime later. When making repairs, use only genuine Marwin Valve parts, available for immediate shipment from the factory.

### Storage

1. Store off the floor.
2. Store in a climate controlled building.
3. Store in a clean and dry area.

### For Future Reference

1. Actuator Model Number \_\_\_\_\_
2. Actuator Enclosure Type    NEMA 4 \_\_\_\_\_ NEMA 4X \_\_\_\_\_ NEMA 7 \_\_\_\_\_ NEMA 4&7 \_\_\_\_\_
3. Actuator Output Torque (lb.-in.) \_\_\_\_\_
4. Motor Characteristics, Voltage \_\_\_\_\_ Hertz \_\_\_\_\_ Phase \_\_\_\_\_
5. Actuator Serial Number \_\_\_\_\_
6. Date of Installation \_\_\_\_\_ Put in Operation \_\_\_\_\_
7. Valve Data:
  - 7a. Manufacturer \_\_\_\_\_
  - 7b. Style & Figure Number \_\_\_\_\_
  - 7c. Size \_\_\_\_\_
  - 7d. End Connection \_\_\_\_\_
  - 7e. Material of Construction    Body \_\_\_\_\_ Stem & Ball \_\_\_\_\_
  - 7f. Brake Away Torque \_\_\_\_\_ lb.-in. @ \_\_\_\_\_ psi differential pressure
  - 7g. Other Information \_\_\_\_\_

### Media

1. System Media \_\_\_\_\_
2. Temperature \_\_\_\_\_ °F Maximum \_\_\_\_\_ °F Minimum
3. Pressure (PSI) \_\_\_\_\_

It is important to select the actuator size and options to meet the valve and system specifications and requirements. If the actuator is not properly sized for the valve and application, the life will be shortened or it may not work at all.

## Tools Required

ER-1	
Cover Screws	9/64" Allen wrench
Terminal Strip Screws	1/8" wide flat head screw driver
Cam Setscrew	5/64" Allen wrench
Mounting Pad Screws	3/8" socket
ER-2 and ER-3	
Cover Screws	NEMA Standard enclosure - Phillips head screwdriver; Deep Base enclosure - 9/64" Allen wrench. <b>NEMA 7</b> enclosure - 7/16" socket
Position Indicator	5/64" Allen wrench
Terminal Strip Screws	1/8" wide flat head screwdriver
Cam Setscrew	5/64" Allen wrench
Mounting Pad Screws	3/8" socket
ER4-15	
Cover Screws	NEMA 4 enclosure - 5/32" Allen wrench. <b>NEMA 7</b> enclosure - 7/16" socket
Terminal Strip Screws	3/16" wide flat head screwdriver
Cam Setscrews	5/64" Allen wrench
Mounting Pad Screws	1/2" socket
ER-20 and ER-38	
Cover Screws	7/16" socket
Terminal Strip Screws	3/16" wide flat head screwdriver
Cam Setscrew	5/64" Allen wrench
Mounting Pad Screws	9/16" socket
ER-50-140	
Cover Screws	1/2" socket
Position Indicator	5/64" Allen wrench
Terminal Strip Screws	3/16" wide flat head screwdriver
Cam Setscrew	5/64" Allen wrench
Mounting Pad Screws	3/4" socket

Additional tools will be required for the screws to mount the valve to the actuators.

Suggestion Maximum Torque Values for Fasteners in in.-lbs.				
Screw Size	Low Carbon Steel	18-8 SS	316 SS	Aluminum
2-56	2.2	2.5	2.6	1.4
4-40	4.7	5.2	5.5	2.9
6-32	9	10	10	5
8-32	18	20	21	10
10-24	21	23	24	13
10-32	30	32	33	19
1/4-20	65	75	79	45
5/16-18	129	132	138	80
3/8-16	212	236	247	143
1/2-13	465	517	542	313
5/8-11	1000	1110	1160	715

## Installation

The actuator is shipped in the open position from the factory. It is important to make sure the valve and actuator are in the same position before mounting the actuator on the valve.

1. Manually open valve.
2. Remove the valve mechanical stops. **CAUTION: DO NOT REMOVE** any parts necessary for the proper operation of the valve, i.e., packing gland, gland nut, etc.
3. Check again that the valve and actuator are in the same position.
4. Install mounting hardware on valve; do not tighten bolts securely at this time. Mount actuator to valve; once actuator screws have been started securely tighten all nuts and bolts. NOTE: Actuator conduit entry is normally positioned perpendicular to pipe line.
5. Remove actuator cover. Indicator and handwheel, if any, must be removed first. Cover may stick to gasket after fasteners are removed. It can generally be removed by slapping the sides with an upward motion. If this doesn't work, it may be necessary to carefully pry between the gasket and the cover. Be careful not to damage the gasket, which is glued to the base.
6. Wire actuator, using the wiring diagram inside cover. **CAUTION: Be sure power is off at the main power box.**
7. Turn on power to actuator. **CAUTION: Use extreme caution, as there are live circuits that could cause electrical shock or death.**
8. Operate the valve to the close position, check the alignment. After checking the alignment of the valve port, calibration may be required.

### To Set the Open Position:

**CAUTION: Valves with mechanical stops may be damaged or cause damage to the actuator if allowed to travel too far open.**

1. Operate valve to the open position by applying power to terminal connections #1 and #2, the valve will rotate counter-clockwise (CCW) viewing top of actuator. **NOTE:** When the actuator is in the open position the setscrew securing the cam to the shaft will be easily accessible.
  - a. If valve does not open completely:
    - i. Loosen 8-32 set screw in top cam.
    - ii. Rotate cam clockwise (CW) until the switch makes contact (listen carefully for a slight click). The valve will begin to rotate CCW. By making small incremental CW movements of the cam the valve can be positioned precisely in the desired position.

- iii. Securely tighten the setscrew.
- b. If valve traveled too far open:
  - i. Apply power to terminal connections #1 and #3, the valve will begin to rotate CW, allow it to travel to the mid position.
  - ii. Follow directions in section a of "To set open position".

### To Set the Closed Position:

**CAUTION: Valves with mechanical stops may be damaged or cause damage to the actuator if allowed to travel too far closed.**

1. Operate valve to the closed position by applying power to terminal connections #1 and #3: the valve will rotate CW viewing the top of the actuator. **NOTE:** When the actuator is in the closed position the setscrew securing the close cam to the shaft will be accessible.
  - a. If valve did not close completely:
    - i. Loosen 8-32 set screw in bottom cam.
    - ii. Rotate cam CCW until the switch makes contact (listen for a slight click). The valve will begin to rotate CW. By making small CCW incremental movements of the cam the valve can be positioned precisely in the closed position.
    - iii. Securely tighten the setscrew.
  - b. If the valve has traveled too far closed:
    - i. Apply power to terminal connection #1 and #2: the valve will begin to rotate CCW. Allow to rotate to the mid position.
    - ii. Follow directions in section a of "To Set Closed Position."

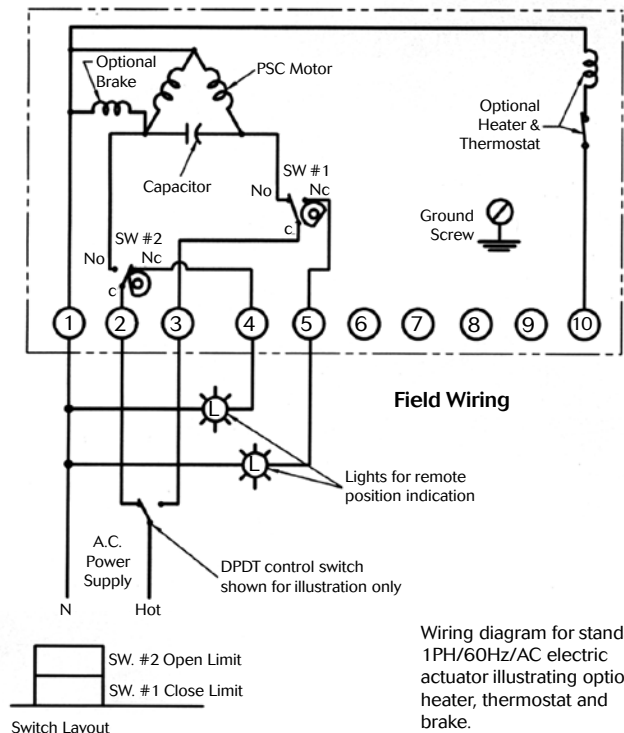

**Notes:**

Power to terminals one and two opens the valve (CCW rotation).

Power to terminals one and three closes the valve (CW rotation).

Terminals four and five are for light indication.

Wiring diagram illustrates the actuator in the open position.

**Typical wiring diagram. Specific wiring diagram inside cover of each unit, or see Marwin website.**

---

## Maintenance

---

After your Marwin Valve electric actuator has been properly installed there is little or no maintenance ever required. The gear train has been permanently lubricated at the factory and requires no routine maintenance. In the event it becomes necessary to perform maintenance on the actuator:

1. Turn off power to the actuator before removing the cover.
2. Place a lock out pad on the power source.
3. Upon assembly we recommend lubrication using Lubriplate EMB grease.
4. Calibrate before placing back into hazardous location.
5. Rewire actuator before removing lock out pad.
6. Remove lock out pad after cover is replaced and secured.

---

## Duty Cycle

---

Marwin actuators rated 100 lb-in up to 1500 lb-in output torque are rated for 25% duty cycle at 100% ambient temperature at rated torque (75% duty cycle motors are available upon request). Actuators rated for 2000 lb-in output torque and greater are rated for continuous duty. All direct current (dc) motors are rated for 75% duty cycle.

---

## Thermal Overload

---

All alternating current (ac) motors are equipped with thermal over load protection to guard the motor against damage from overheating.

---

## Mechanical Overload

---

Marwin actuators are all designed to withstand stall conditions. It is not recommended to subject the unit to repeated stall conditions; however, should it occur the actuator would not experience gear damage.

---

## Recommended Spare Parts

---

Two Position Actuators: Set of cams and switches.

Modulating Actuators: Set of cams, switches, feedback potentiometer and a positioner card.

---

## NEMA 7 Enclosure

---

In general, operation and maintenance of a NEMA 7 electric actuator is no different than that of a NEMA 4 electric actuator. However, there are some precautions that must be followed.

1. **DO NOT** install in ambient temperatures above 140°F.
2. **DO NOT** under any circumstances remove the actuator cover while in a hazardous location, this could cause ignition of hazardous atmospheres.
3. **DO NOT** under any circumstances use a NEMA 7 electric actuator in a hazardous location that does not meet the specifications for which the actuator was designed. The actuator is clearly tagged with the NEMA classification it was designed for.
4. Mount, test and calibrate actuator on valve in non-hazardous location.
5. When removing the cover care must be taken not to scratch, scar or deform the flame path of the cover or base of the actuator; this will negate the NEMA 7 rating of the enclosure.
6. When replacing the cover on actuators rated NEMA 4 and 7 take care that the gasket is in place to assure the proper clearance after the cover is secured. After securing the cover screws check the clearance between the cover and the base, a 0.002" thick by 1/2" wide feeler gauge may not enter between the two mating faces more than 0.12".
7. All electrical connections must be to state and local codes and in accordance with the specifications for which the unit is being used.

After proper installation, the actuator will require little or no maintenance. In the event maintenance is required, remove it from the hazardous location before attempting to work on it. If the actuator is in a critical application and down time is not permitted, it is advisable to have a spare actuator in stock.

---

## Warranty

---

Richards Industries (RI) warrants that for a period of twelve months from the date of shipment it will either repair or replace, at its option, any of its products, which prove to be defective in material or workmanship. This warranty does not cover damage resulting from causes such as abuse, misuse, modification or tampering. This warranty is extended only to the immediate purchaser of RI's product and is not transferable. To obtain service

under this warranty, the purchaser must first obtain a return authorization number from RI. Products must be returned to RI freight prepaid for evaluation. If the unit failed due to poor workmanship or materials the unit will be repaired or replaced. The unit will be returned ground freight paid by RI, if air shipment is requested the purchaser shall pay the difference. This warranty is in lieu of all other obligations, liabilities or expressed warranties. Any implied warranties, including any implied warranty of merchantability are hereby expressly excluded. In no event shall RI be liable for special, incidental or consequential damages arising in connection with the use of its products, or for any delay in the performance of this warranty due to causes beyond its control.

---

## Troubleshooting

---

### **Actuator does not respond to control signal.**

- Power not on. Turn on power.
- Actuator wiring wrong. Check wiring diagram and rewire.
- Wrong voltage. Check power supply and make appropriate change.
- Thermal overload activated. Allow motor to cool, actuator will automatically reset.
- Actuator and valve in opposite positions when actuator was mounted. Remove actuator, rotate 90° and remount.

### **Actuator will not open or close completely.**

- Travel limits set wrong. Reset cams.
- Valve torque too high for actuator. Install correct size actuator.
- Mechanical stops not removed. Remove stops.  
CAUTION: Do not remove any part required for proper operation.

### **Valve oscillates.**

- Valve torque too high for actuator. Install correct size actuator.
- Actuator without brake installed on butterfly valve. Install brake.
- Motor brake out of adjustment. Adjust brake.
- Set screw loose in brake disc. Adjust brake and tighten set screw.

### **Motor runs but output shaft does not rotate.**

- Gear damage or sheared pin. Contact Factory or nearest distributor.

---

## Manual Override Operation Instructions

---

1. Push hand wheel down.
2. Rotate to align slot with flats.
3. Push down a second time to disengage gear train.
4. Rotate hand wheel clockwise to go to open or counter-clockwise to go to close.

Note: Actuator does not have mechanical stops. Do not rotate past open or close position. Use visual indicator to position actuator.

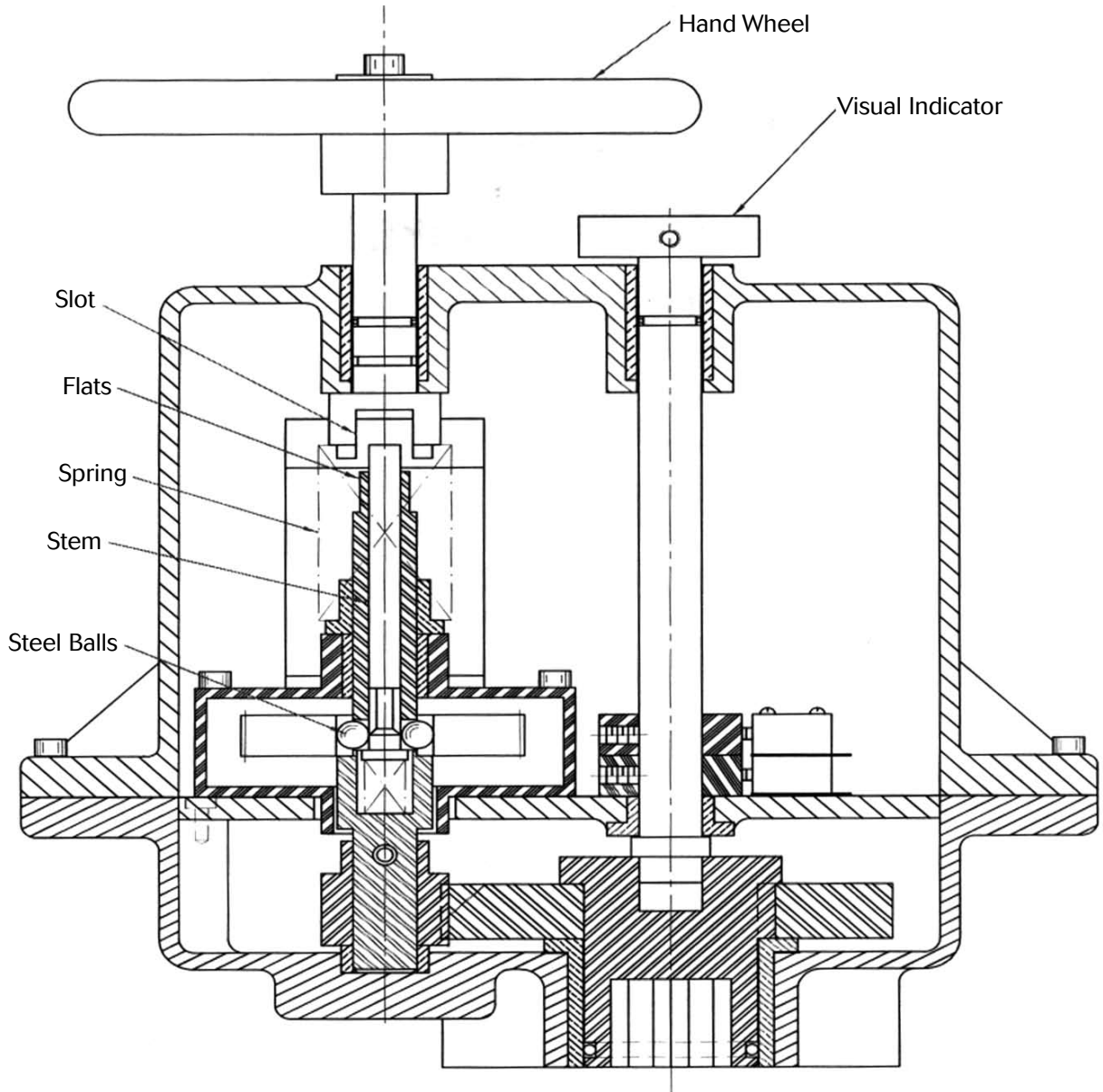

Cross section drawings for ER4-15 Series Nema Type 7  
Enclosure for Class I Groups C & D, Class II Groups E, F & G Div. 1 & 2 with de-clutching manual override

Depending on actuator size and enclosure, manual over ride and visual indicator may be optional equipment that must be specified at time of order.