



MARWIN VALVE

3170 Wasson Road • Cincinnati, OH 45209 USA
Phone 513-533-5600 • Fax 513-871-0105
marwin@richardsind.com • www.marwinvalve.com

I & M UT Series (Pre 2003 Design)

*Installation & Maintenance Instructions for
Marwin UT Series Actuators ~ UT-0A, UT5 thru UT7
(all versions), and UT-0 thru UT-4.5 (Pre 2003 Design)*

Warning: Marwin Valve Ball Valves must only be used, installed and repaired in accordance with these Installation & Maintenance Instructions. Observe all applicable public and company codes and regulations. In the event of leakage or other malfunction, call a qualified service person; continued operation may cause system failure or a general hazard.

Please read these instructions carefully!

Your Marwin Valve product will provide you with long, trouble-free service if it is correctly installed and maintained. Spending a few minutes now reading these instructions can save hours of trouble and downtime later. When making repairs, use only genuine Marwin Valve parts, available for immediate shipment from the factory.

Scope

This manual is intended as a guide to assist customers in the storage, installation, and maintenance of Marwin UT Series Pneumatic Actuators UT-0A, UT-5 thru UT-7 (all versions), and UT-0 thru UT-4 (Pre 2003 design). See photo on back page for further identification.

Main Characteristics

- **Maximum Air Supply:** 116 psi (8 bar)
- **Supply:** dry air (STANDARD). Other fluids or gases are possible if compatible with actuator materials.
- **Temperature:** from -4°F to +185°F (-20°C to +85°C) for standard version with NBR seals;
from -4°F to +302°F (-20°C to +150°C) for HIGH TEMP version (Viton seals);
from -40°F to +185°F (-40°C to +85°C) for LOW TEMP version.
- **Rotation:** 90° stroke with regulation +/-10° in open position.
- **Lubrication:** during assembly, for the actuator life.

Operating Principle

The Marwin UT pneumatic actuator is a quarter-turn rack and pinion type that transforms the linear motion of the pistons (7), due to the thrust caused by the pressure on the surface area, to a 90° rotary motion of the pinion (2).

Double Acting

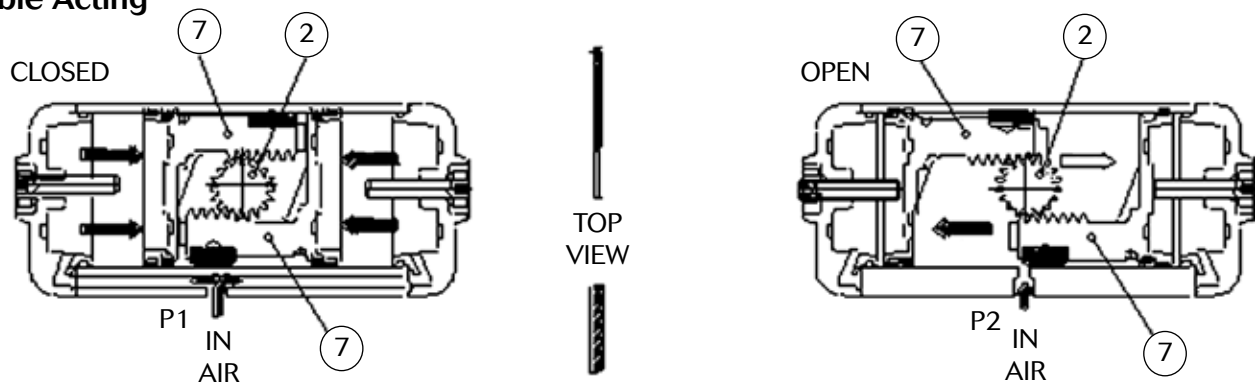

Pressurizing the left or bottom air port (**P1**) fills the external chambers. The action of the pressure on the surface of the pistons (**7**) creates a force (**F**) that pushes them toward the pinion, generating a torque with **CLOCKWISE ROTATION**.

Pressurizing the right or top air port (**P2**) fills the internal chamber. The action of the pressure on the surface of the pistons (**7**) creates a force (**F1**) that pushes them toward the end caps, generating a torque with **COUNTERCLOCKWISE ROTATION**.

Spring Return

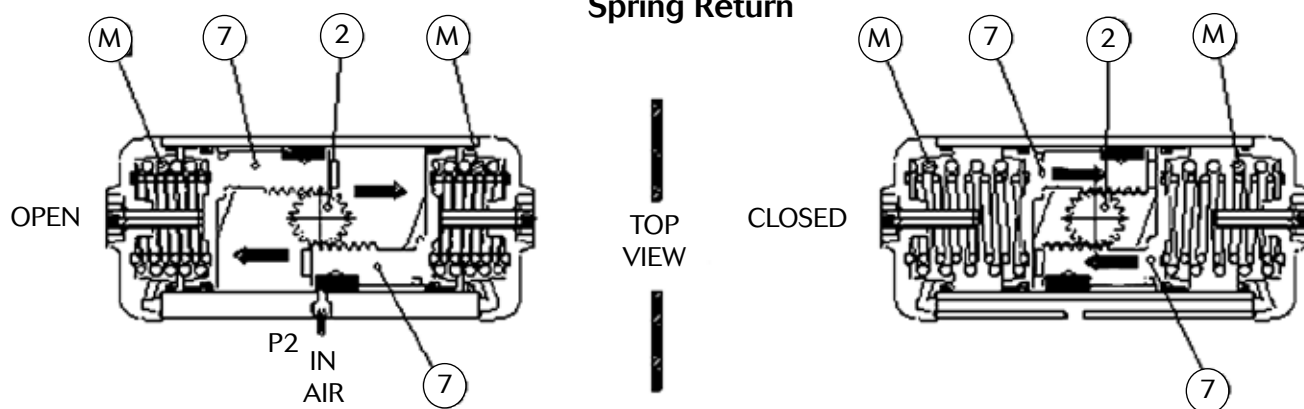

When the pistons (7) are next to the pinion (2) (springs (M) uncompressed), pressurizing the right or top air port (P2) fills the internal chamber. The action of the pressure on the surface of the pistons creates a force (F1) that pushes them toward the end caps, generating a torque with **COUNTERCLOCKWISE ROTATION**.

When the pistons (7) are next to the end caps (springs (M) compressed), de-pressurizing air port (P2), allows the springs to uncompress. The spring force (Fm) pushes the pistons toward the pinion, generating a torque with **CLOCKWISE ROTATION**.

Storage

For applications where the actuator is not put into immediate service, it is recommended that the actuator be kept in a clean and dry location with ample protection from the environment. For unmounted actuators, the original packing box helps in optimizing the storage.

For a long storage period, we recommend periodically pressurizing the chambers to completely cycle the actuator.

The actuators have two air ports, which should be plugged during storage to avoid any intrusion.

Maintenance

The lubrication used during the assembly of the actuator, and the self-lubricating material used in the guides, gives a life of one million cycles for normal working conditions. When replacing worn seals, it is recommended that the guides be replaced as well to ensure best actuator performance.

Disassembly

1. **Disconnect all pneumatic and electrical supplies from the actuator.**
2. Remove any accessory from the actuator that could be damaged.
3. Remove actuator from valve (noting the valve position, actuator position, and actuator orientation on the valve for correct reinstallation).
4. Place the actuator on a support with the same male drive of the pinion female connection, in order to easily execute the following steps:

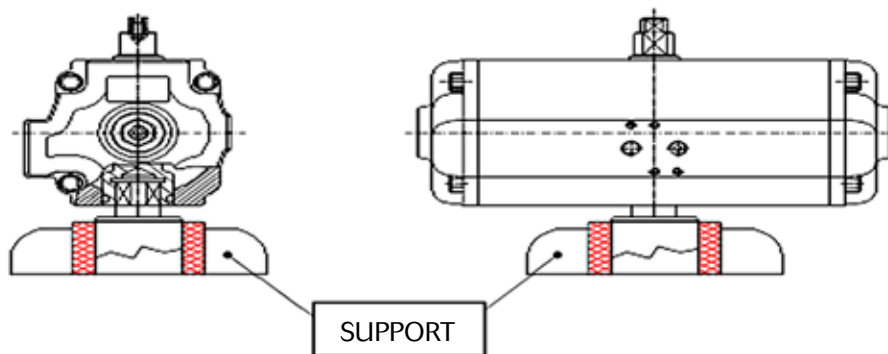

- Before starting the disassembly, **verify** by the stamped marking on the body if the actuator is double acting (DA) or spring return (SR).

For DOUBLE ACTING actuator:

- Slowly remove the end caps screws (20) from each end cap (18,19) using a diagonal pattern.

FOR SPRING RETURN actuator:

- Slowly disengage the screws (20) part way from each end cap (18,19), to allow the springs to fully uncompress. Use a diagonal pattern.
- Rotate the actuator body (1) in a clockwise direction in respect of the pinion (2), so that the pistons (7), pushing the adjustment screws (14), will eject the end caps (18,19), and that at the end of the rotation the pistons (7) will be disconnected from the pinion (2).
- Take out the pistons (7) from the body (1).
- Remove pinion snap ring (6) from its place on the pinion (2).
- Take away the spacer ring (5).
- Carefully remove the pinion (2) from the body (1).

Actuator Parts

Note:

UT-0A, UT-6 and UT-7 sizes have air supply ports arranged vertically, and require NAMUR base adaptor 26-00002 to convert parts to horizontal arrangement for NAMUR direct mount solenoid valves.

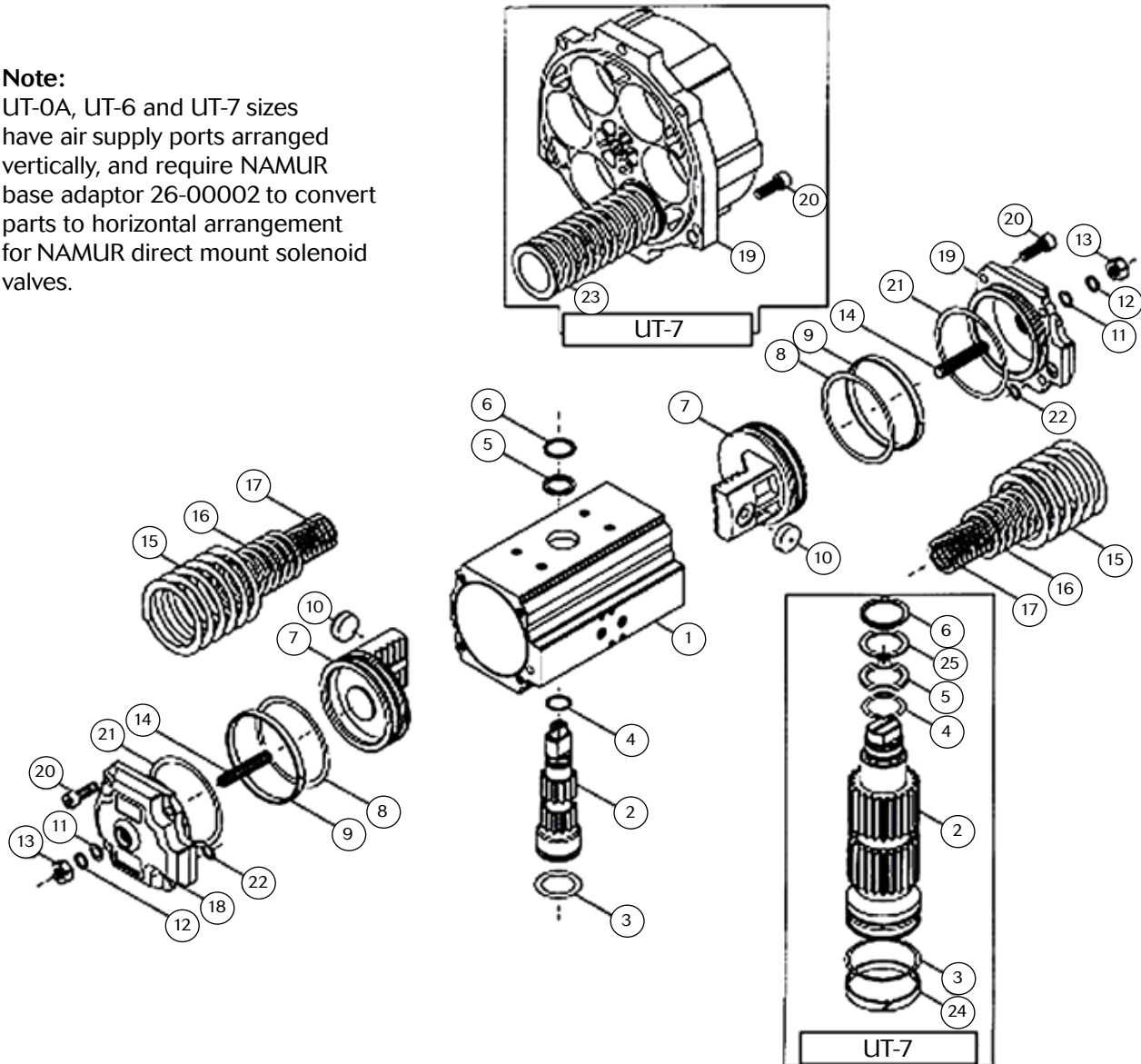

SPRING SETTING for UT-0 to UT-4				
Set	External Spring	Central Spring	Internal Spring	Air Supply, psi/(bar)
01	1	—	1	36-44 / 2.5-3
02	2	—	0	44-58 / 3-4
03	1	—	2	44-73 / 3-5
04	2	—	1	58-80 / 4-5.5
05	2	—	2	73-87 / 5-6

SPRING SETTING for UT-5 and UT-6				
Set	External Spring	Central Spring	Internal Spring	Air Supply, psi/(bar)
01	0	2	0	36-44 / 2.5-3
02	2	0	0	44-58 / 3-4
03	1	2	0	44-73 / 3-5
04	2	0	2	58-80 / 4-5.5
05	2	2	0	73-87 / 5-6
06	2	2	2	87-102 / 6-7

PRETENSIONED SPRINGS For UT-7		
Set	Side 1	Side 2
01	2	3
02	3	3
03	3	4
04	4	4
05	4	5
06	5	5
07	5	6
08	6	6

MATERIAL SPECIFICATIONS					
Item	Description	Material	Treatment	Qty. DA	Qty. SR
1	Body	Extruded Aluminum	Hard Anodized	1	1
2	Anti-Blowout Pinion	Steel	Nickel Plated	1	1
3* (R)	Lower Pinion O-Ring	NBR 70 Shore		1	1
4* (R)	Top Pinion O-Ring	NBR 70 Shore		1	1
5* (R)	Pinion Spacer Ring	PTFE 15% Graphite		1	1
6 (R)	Piston Snap Ring	Steel	Nickel Plated	1	1
7	Piston	Die Cast Aluminum		2	2
8* (R)	Piston O-Ring	NBR 70 Shore		2	2
9* (R)	Anti-Friction Ring	PTFE 15% Graphite		2	2
10* (R)	Piston Thrust Block	PTFE 15% Graphite		4 6 ***	4 6 ***
11* (R)	Stop Bolt O-Ring	NBR 70 Shore		2	2
12	Stop Bolt Washer	Stainless Steel A2		2	2
13	Stop Bolt Retaining Nut	Stainless Steel A2		2	2
14	Stop Bolt	Stainless Steel A2		2	2
15	External Spring	Steel	Zinc Phosphate	0	See Table
16	Central Spring	Steel	Zinc Phosphate		
17	Internal Spring	Steel	Zinc Phosphate		
18	Left End Cap	Die Cast Aluminum	Painted	1	1
19	Right End Cap	Die Cast Aluminum	Painted	1	1
20	End Cap Fixing Screw	Stainless Steel A2		8 12 ***	8 12 ***
21 (R)	End Cap O-Ring	NBR 70 Shore		2	2
22 (R)	O-Ring for Air Supply Hole	NBR 70 Shore		2	2
23	Comp. Spring (UT-7 only)	Steel	Zinc Phosphate	0	12
24* (R)	Anti-Friction Ring (UT-7 only)	PTFE 15% Graphite		1	1
25 (R)	Washer (UT-7 only)	Stainless Steel A2		1	1

* Parts subject to wear. (R) Repair Kit Item. 6&12 Valid for UT-7 only.

Assembly

1. Clean the components before proceeding with the assembly.
2. Lightly grease the internal chamber of the body (1) and the seals on the pistons. We suggest the use of an extreme pressure lithium based grease such as **Kluber Centoplex 2 EP**.
3. Carefully insert the pinion (2) into the body (1), so that the two pinion flat surfaces are parallel to the axis of the body and secure with spacer ring (5) and pinion snap ring (6).

Assembly Possibilities - Top View

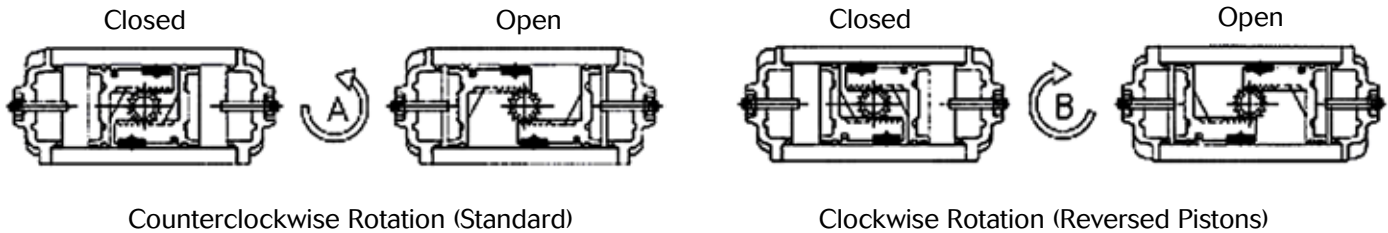

4. Insert the pistons (pre assembled and greased) into the body as shown here below.
5. Push the pistons (7) into the body (1) until the piston teeth are stopped by the teeth of the pinion (2).
6. Keeping a soft pressure with the hands on the pistons (7), rotate the body (1) in clockwise rotation in respect to the pinion (2) until feeling two clicks, when the pistons engage with the pinion (2).
7. Now rotate the body (1) in counterclockwise rotation, and verify that at the end of the rotation the two pinion flat surfaces are at right angles to the axis of the body.

NOTE: Correct assembly gives symmetric stroke of the pistons, which can be verified by measuring distance from each end face of the body. These distances should be equal.

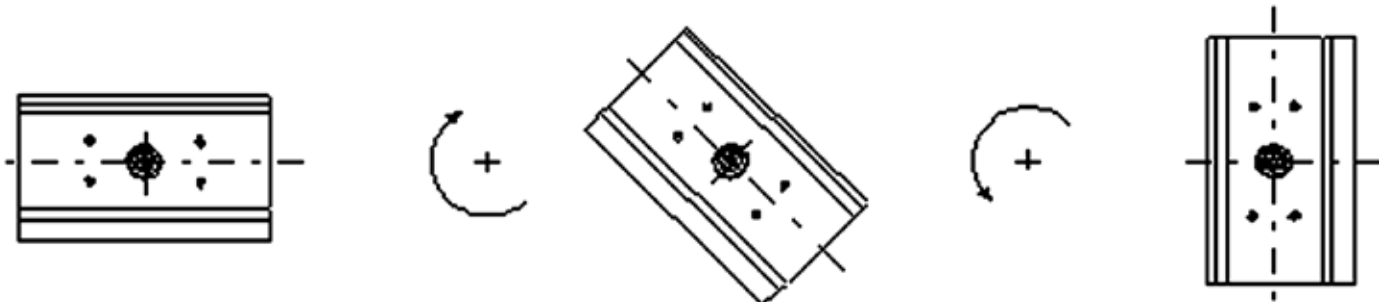

FOR DOUBLE ACTING ACTUATORS

8. Assemble the end caps (18,19) to the body (1) with the screws (20), using a diagonal bolting pattern.

FOR SPRING RETURN ACTUATORS

9. **With the pistons in the CLOSED position**, insert the springs in spring set (M) into the body (1), putting them in the piston (7) recess. Then assemble the end cap (18,19) on the springs. Center the end cap recess on the springs. Assemble the screws (20), using a diagonal bolting pattern to tighten each screw a little at a time, so that the springs are uniformly compressed, until end cap (18) is completely closed. **Note: A press and guard are suggested for performing this operation on actuator sizes UT-5 and UT-6.**
10. Repeat the operation on the other side.
11. Operate the actuator to verify the correct functioning before re-installing it.

Stroke Adjustment

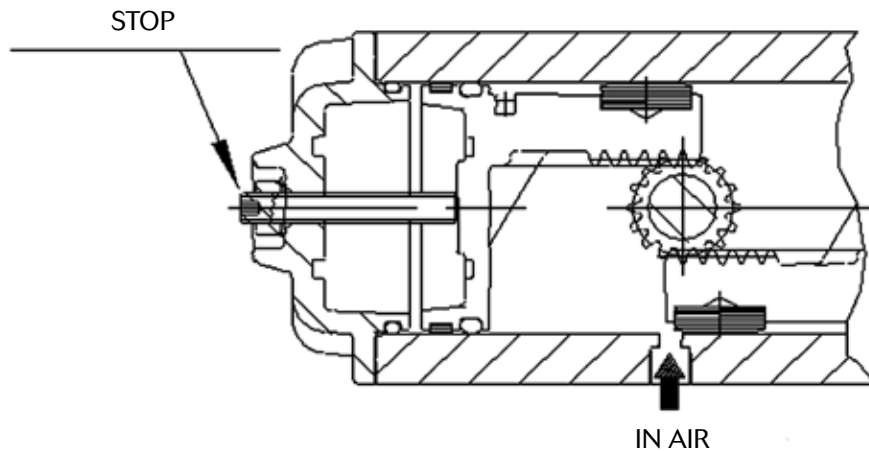

Closed

- Adjust closed position of valve by loosening bracket bolts, twisting actuator slightly, and retightening bolts. Repeat until desired closed adjustment is reached.

Open

Adjusting the stop bolts reduces or increases the piston stroke and opening rotation

- Remove air supply or move the pistons to the closed position.
- Adjust one bolt only. Back off and leave second bolt until after desired open adjustment is reached.
- Move the pistons to the open position and verify the new adjustment.
- Repeat this operation until desired open adjustment is achieved.
- Restore air supply, and adjust the second bolt until it touches the piston.

2003 versus Pre-2003 Design

Pre 2003 Design

UT-0 Shown

Representative of:

- All UT actuators 0A thru 7 (32-270mm bore) prior to 2003
- UT-0A, and UT-5 thru 7 (32 & 160-270mm bore) only after 2003

2003 Design

UT-0 Shown

Representative of:

- UT Actuators 0 thru 4.5 (52-140mm bore) after 2003

