



3170 Wasson Road • Cincinnati, OH 45209 USA
Phone 513-533-7340 • Fax 513-533-7343
E-Mail: marwin@richardsind.com • www.marwinvalve.com

I&M 600 Series

Installation & Maintenance Instructions for Marwin 600 Series Ball Valves

Warning: Marwin Valve ball valves must only be used, installed, and repaired in accordance with these Installation & Maintenance Instructions. Observe all applicable public and company codes and regulations. In the event of leakage or other malfunction, call a qualified service person; continued operation may cause system failure or a general hazard.

Please read these instructions carefully!

Your Marwin Valve product will provide you with long, trouble-free service if it is correctly installed and maintained. Spending a few minutes now reading these instructions can save hours of trouble and downtime later. When making repairs, use only genuine Marwin Valve parts, available for immediate shipment from the factory.

Scope

This manual is intended as a guide to assist customers in the storage, installation, and maintenance of Marwin 600 Series Ball Valves. Subsequent additions or special instructions will be provided for special ball valves, critical service, or customer requirements.

Applicability

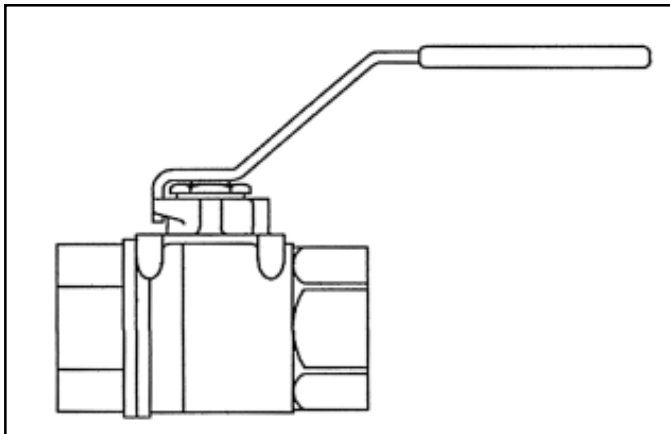

1. This manual is applicable to the 600 Series Marwin ball valves.

Caution

To help prevent injury to personnel or damage to equipment, please read this section completely before performing any operations.

1. Valve pressure ratings are based on many variables, including valve series and size, as well as body, seat and bolt material. Verify that application does not exceed the pressure or temperature rating on the nameplate.
2. **ALWAYS** depressurize the line with the valve in the **OPEN** position before disassembly. Cycle valve in depressurized line before removing valve.
3. Wear protective equipment and take appropriate precautions to safeguard against injury caused by the discharge of trapped fluids.
4. Use only Marwin recommended spare parts for maintenance.
5. To ensure safety and maintain warranty, never modify valve in any way without prior approval from Marwin.

Storage

A petroleum-based oil (silicone free) is used as lubrication on all internal surfaces. This may be removed with a solvent if found objectionable. All valves are adequately packed in a strong cardboard case in such a way as to avoid any possible damage during transport and storage.

CAUTION: If ball valves are not destined for immediate use, the following precautions should be taken:

1. If possible, leave the ball valves in their packing cases during the period of storage.
2. Ball valves must remain in open position during this time.
3. In order to prevent damage, protective plastic covers on valve ends should not be removed until immediately prior to installation.
4. It is advisable to store the valves in waterproof conditions. Ball valves should be protected to safeguard against humidity, moisture, dust, dirt, sand, mud, salt spray, and seawater.

5. Valves to be stored for a long period of time should be checked by the quality control personnel every six months; every three months when valves are automated.

Maintenance During Storage Period

- Internal surface should be inspected to check for dust or other foreign objects.
- Rust or dust must be removed by cleaning with proper solvent.
- After cleaning, ball valves must be lubricated with an adequate lubricant.
- Ball valves should be operated for at least two complete cycles before installing or returning to storage.

Installation

The ball valves may be installed in any position using Standard Pipe Fitting Practice.

CAUTION: Before installation of the valve:

1. Pipe must be free of tension both during and after installation.
2. Pipe must be flushed to clean dirt, welding residues, etc. which would damage ball or seats.
3. The valve should be kept in OPEN POSITION during installation and protective plastic covers must be removed only at the moment of installation.
4. Before shipment, the ball is lubricated with a pure Vaseline oil. This can be easily removed with an application compatible solvent if required.
5. If the valve was specified to be tested per ASTM 16.34, there may be some trapped water between the ball and the body cavity. This can be removed by partially opening the valve, thereby exposing the cavity to the through port of the ball.
6. Special care should always be taken when installing automated ball valves that the ball is in the proper position.

Installation of Threaded Ends

1. Unless otherwise specified, pipe threads are American National Standard Taper Pipe Threads (NPT) per ANSI B1.20.1, and require that a pipe sealant be used.
2. Use an anti-seize thread sealant to seal and prevent galling.
 - a. Marwin recommends PTFE-based liquid sealant or Grafoil tape as thread sealants.
 - b. Notes:
 1. Use all pipe sealant products in accordance with the manufacturer's instructions and good piping practices.
 2. Correct lubrication of stainless steel pipe threads is especially important to prevent galling.
3. To prevent distortion or damage to the valve, do not apply torque through the valve. When tightening valve, use wrench on the end nearest the pipe being tightened.
4. Always leak test the system before using.

Installation of Soldered-End Ball Valves

1. Use standard pipe soldering practices for standard trim packages (i.e. Teflon seats and seals).

Manual Operation

1. Open and close the valve by turning the handle one-quarter turn (90°).
2. Valve is in open position when handle is in line with the pipe.
3. Valve is in closed position when the handle is perpendicular to the pipe.

Maintenance

Before starting maintenance, please read information contained in the **Caution Section** of the manual.

1. Open and close the ball valve at least once to release the pressure completely from valve body.
2. Ball valves, if correctly used, normally do not need any internal lubrication and maintenance.

Valve Disassembly/Reassembly

Note: The 600 Series ball valves are not designed for rebuilding, nor is it economical to do so. Should the valve leak, complete replacement is recommended. However, a spare parts kit may be special ordered at customer request.

Troubleshooting

A. Stem Leakage

1. If leakage persists, replace the valve.

B. Body Seal Leakage

1. Check the torque of the end cap. Replace valve if leakage persists.

C. In Line or Seats Leakage

1. Check to be sure valve is in fully closed position. If leakage persists the valve must be disassembled and damaged parts replaced.



3170 Wasson Road • Cincinnati, OH 45209 USA
Phone 513-533-7340 • Fax 513-533-7343
Phone Toll-Free: 800-628-2583 (USA)
E-Mail: marwin@richardsind.com
www.marwinvalve.com