

40/41 Series

Rotary Positioners

- The 40 Series pneumatic (3-15 psi) and 41 Series electro-pneumatic (4-20mA) rotary positioners are advanced control devices which provide unparalleled stability in difficult environments
- Rugged aluminum housing with a triple corrosion-resistant interior and exterior coating that resists harsh environments
- Bleed pilot valve reduces air consumption by more than 50%
- Precise calibration with simple SPAN and ZERO adjustments
- Unique magnetic 4-20mA I/P converter provides automation compensation for supply pressure, atmospheric pressure and ambient temperature changes, and is unaffected by electromagnetic fields
- Precision zero-hysteresis coupling system provides superior accuracy and repeatability by eliminating "slop"
- Stainless steel gauges standard

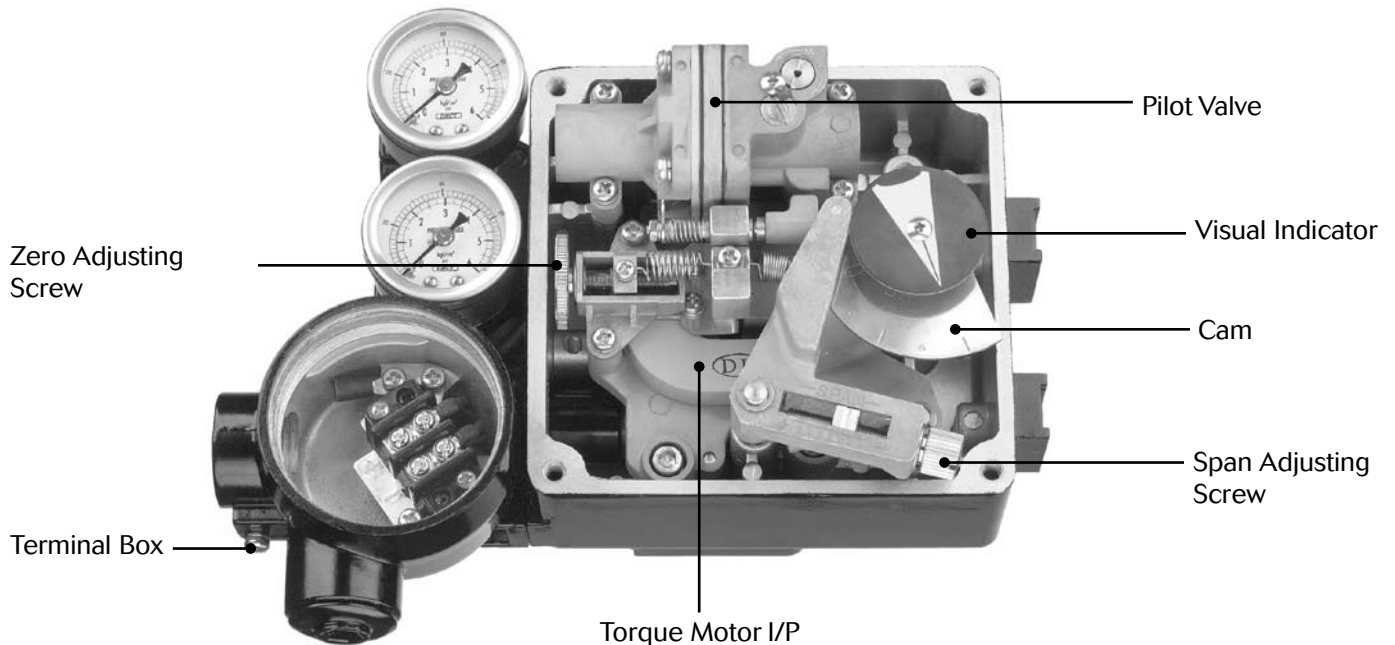

Marwin Valve, a division of Richards Industries

3170 Wasson Road • Cincinnati, OH 45209

513.533.7340 • 800.628.2583 • 513.533.7343 (f)

marwin@richardsind.com • www.marwinvalve.com

Marwin Valve 40/41 Series – Specifications

40/41 Series Technical Specifications

Specification Information – 3-15 psi Pneumatic	
Description	Specification
Input Signal	3-15 psig (0,2-1,0 bar) Split range available
Impedance	N/A
Stroke Range	0 - 90°
Supply Range	20-100 psig (1,4-6,9 bar)
Air Delivery	7 SCFM (198 std. liters/min)
Air Consumption	0.26 SCFM (7,4 std. liters/min)
Operating Temp.	-4° to 158°F (-20° to 70°C)
Linearity	+/-2%
Hysteresis	1% max.
Sensitivity	+/-0.5%
Repeatability	+/-0.5%
Pneumatic Connections	1/4" NPT – Supply/Outlet 1/8 NPT – Gauge Ports
Enclosure	Designed to NEMA 4, 4X
Weight	Approx. 4.8 lbs (2,2 kgs)

Specification Information – 4-20mA Electro- Pneumatic	
Description	Specification
Input Signal	4-20mA @ 24 VDC Split range available
Impedance	250 +/- 15 ohms
Stroke Range	0 - 90°
Supply Range	20-100 psig (1,4-6,9 bar)
Air Delivery	7 SCFM (198 std. liters/min)
Air Consumption	0.15 SCFM (4,2 std. liters/min)
Operating Temp.	-4° to 158°F (-20° to 70°C)
Linearity	+/-2%
Hysteresis	1% max.
Sensitivity	+/-0.5%
Repeatability	+/-0.5%
Pneumatic Connections	1/4" NPT – Supply/Outlet 1/8 NPT – Gauge Ports
Enclosure	Designed to NEMA 4, 4X
Weight	Approx. 6.5 lbs (2,9 kgs)

Principle of Operation – Rotary Valve

As the control signal increases, the plate spring of the torque motor works as a pivot. As the armature receives this rotary torque in the counter-clockwise direction, the counterweight is pushed to the left, the clearance between the nozzle and the flapper will increase, and the nozzle back pressure will decrease. As a result, the exhaust valve of the pilot valve moves to the right, the output pressure of OUT1 increases (as OUT2 decreases) to move the valve actuator.

The movement of the actuator rotates the feedback shaft and spring. The actuator stays in the position where the spring force is balanced with the force generated by the input current in the torque motor. The compensation spring is for direct feedback of the motion of the exhaust valve, and is connected to the counter weight to enhance the stability of the loop. The zero point is adjusted by changing the zero adjust-ment spring tension.

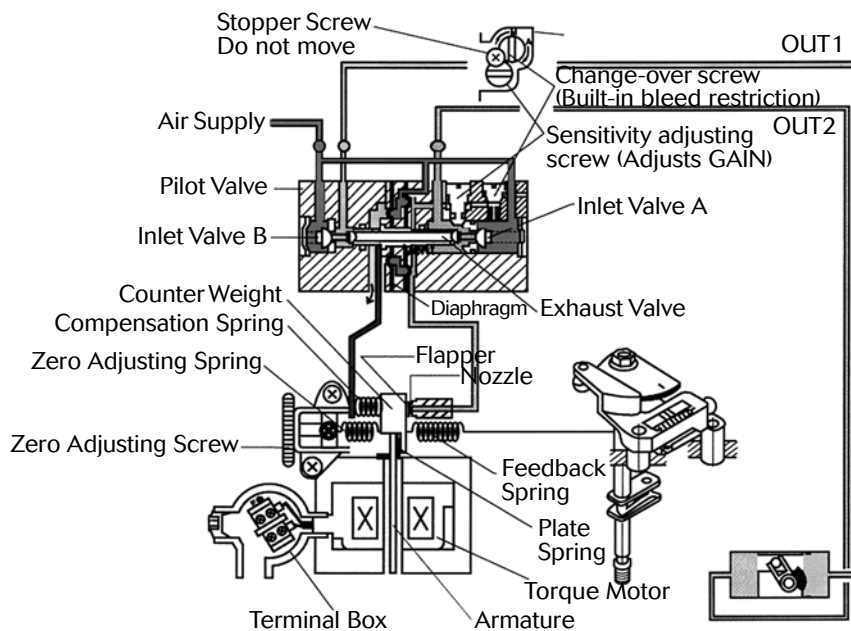

Marwin Valve 40/41 Series – Dimensions

40/41 Series Dimensions – inches (mm)

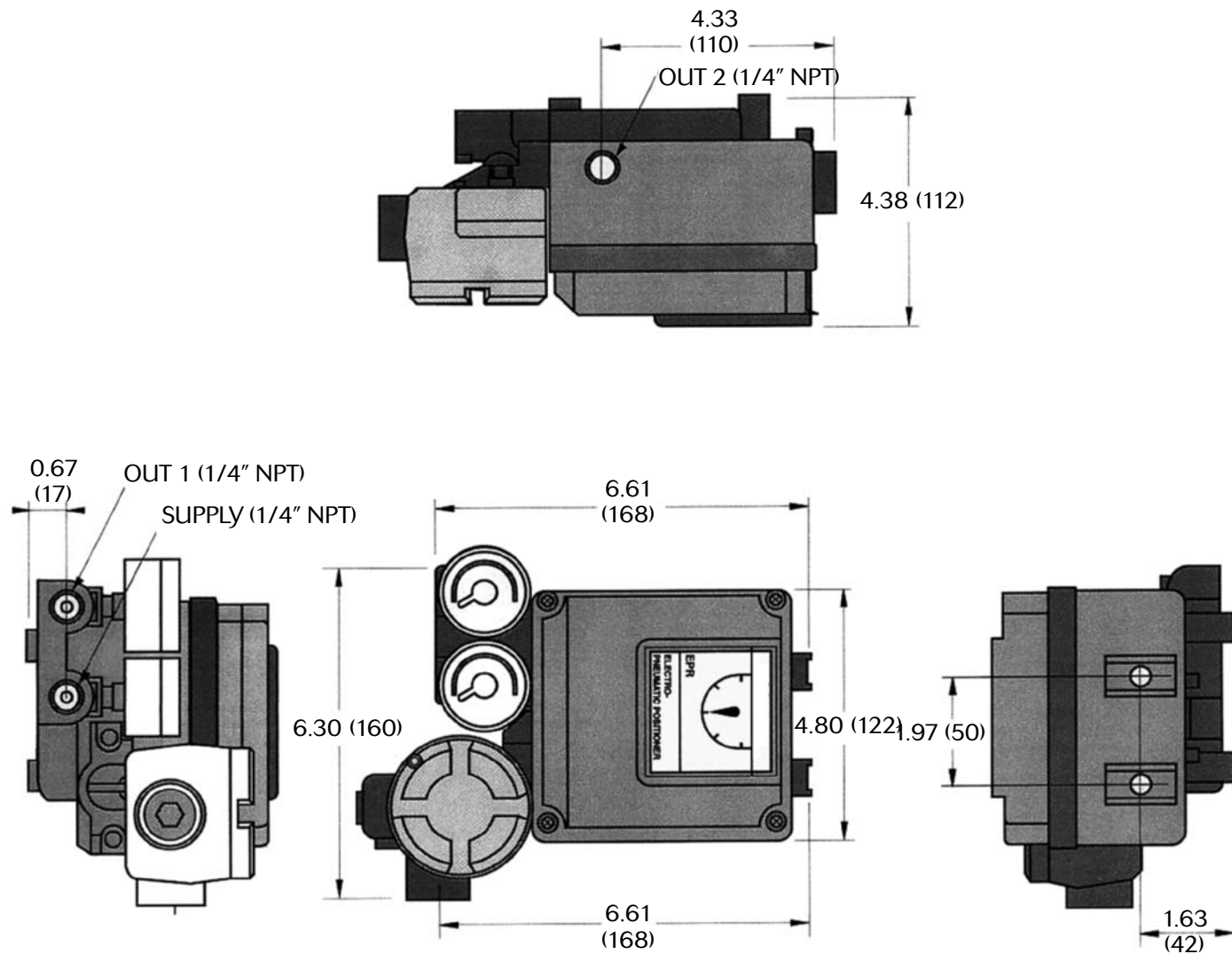

Note: Series 40/41 air supply pressure gauges have dual scale 0 - 150 psi and 0 - 10 bar.

Series 40 air control signal pressure gauge has dual scale 0 - 30 psi and 0 - 2 bar.

Marwin Valve 40/41 Series – Specifications

40/41 Series Piping Configuration

Spring-Return Actuators

Reverse Acting – Actuator rotates **Counter-Clockwise** as input signal increases. Cam should be set with **RA** upwards (standard factory setting)

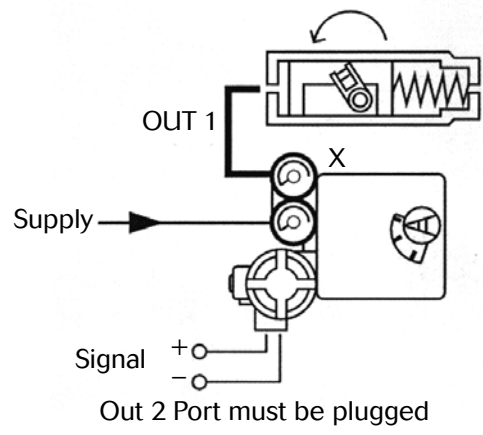

Double-Acting Actuators

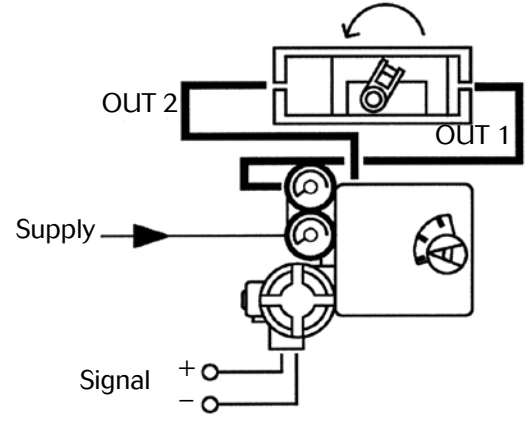

Spring-Return Actuators

Direct Acting – Actuator stem rotates **Clockwise** as input signal increases. Cam should be set with **DA** upwards

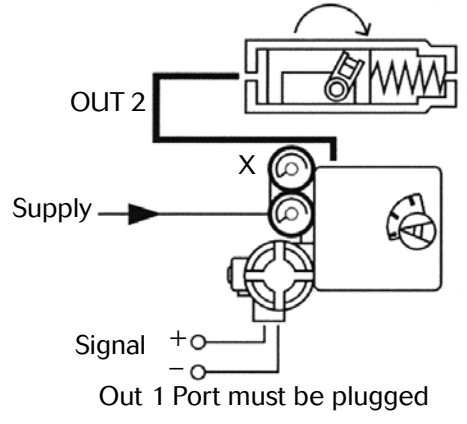

Double-Acting Actuators

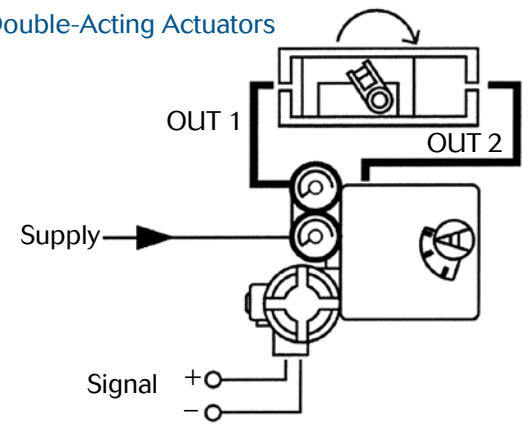

40/41 Series Ordering Schematic

Series	Shaft	Electric Rating	Pilot Valve	Position Feedback	Gauges	Indication
41	N	E	1	N	S	F

Series	
40	Pneumatic (3-15 psi)
41	Electro-Pneumatic (4-20mA)

Shaft	
N	Rotary Namur

Electric Rating	
S	4/4X (standard for 40 Series)
E	EX md II T6 & 4/4x (Standard for 41 Series)

Pilot Valve	
1	Standard Orifice
2	Small Orifice
3	Extra-Small Orifice

Position Indication	
N	None
T	4-20mA Position Transmitter
S	2 SPDT Limit Switches

Pressure Gauges	
S	Standard

Indication	
F	Flat Dial
D	Dome