



3170 Wasson Road • Cincinnati, OH 45209 USA  
Phone 513-533-7340 • Fax 513-533-7343  
E-Mail: marwin@richardsind.com • www.marwinvalve.com

# I&M 3L/T2S33 Series

## Installation & Maintenance Instructions for Marwin 3L/T2S33 Series Three Way Ball Valves

**Warning:** Marwin Valve ball valves must only be used, installed, and repaired in accordance with these Installation & Maintenance Instructions. Observe all applicable public and company codes and regulations. In the event of leakage or other malfunction, call a qualified service person; continued operation may cause system failure or a general hazard.

### Please read these instructions carefully!

Your Marwin Valve product will provide you with long, trouble-free service if it is correctly installed and maintained. Spending a few minutes now reading these instructions can save hours of trouble and downtime later. When making repairs, use only genuine Marwin Valve parts, available for immediate shipment from the factory.

## Scope

This manual is intended as a guide to assist customers in the storage, installation, and maintenance of Marwin 3L/T2S33 Series Three Way Ball Valves. Subsequent additions or special instructions will be provided for special ball valves, critical service, or customer requirements.

## Applicability

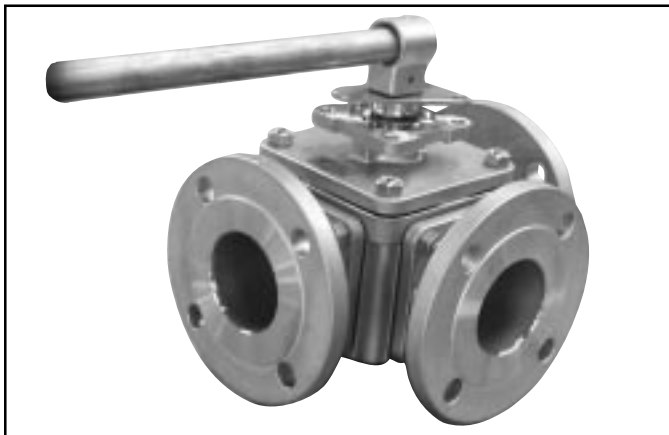

1. This manual is applicable to the 3L/T2S33 (stainless steel) and 3L/T-2R33 (carbon steel) Series Marwin three way ball valves.

## Caution

1. Valve pressure ratings are based on many variables, including valve series and size, as well as body, seat and bolt material. Verify that application does not exceed the pressure or temperature rating on the nameplate.
2. **ALWAYS** depressurize the line with the valve in the **OPEN** position before disassembly. Cycle valve in depressurized

line before loosening bolts.

3. Wear protective equipment and take appropriate precautions to safeguard against injury caused by the discharge of trapped fluids.
4. Use only Marwin recommended spare parts for maintenance.
5. To ensure safety and maintain warranty, never modify valve in any way without prior approval from Marwin.

## Storage

Lubricant is used on all internal surfaces. This may be removed with a solvent if found objectionable. All valves are adequately packed in a strong cardboard case in such a way as to avoid any possible damage during transport and storage.

**CAUTION: If ball valves are not destined for immediate use, the following precautions should be taken:**

1. If possible, leave the ball valves in their packing cases during the period of storage.
2. Ball valves must remain in open position during this time.
3. In order to prevent damage, protective plastic covers on valve ends should not be removed until immediately prior to installation.
4. It is advisable to store the valves in waterproof conditions. Ball valves should be protected to safeguard against humidity, moisture, dust, dirt, sand, mud, salt spray, and seawater.
5. All valves complete with actuators are to be stored in dry conditions.
6. Valves to be stored for a long period of time should be checked by the quality control personnel every six months; every three months when valves are automated.

### Maintenance During Storage Period

- Internal surface should be inspected to check for dirt or other foreign objects.
- Rust or dirt must be removed by cleaning with proper solvent.
- After cleaning, ball valves must be lubricated with an adequate lubricant.
- Ball valves should be operated for at least two complete cycles before installing or returning to storage.

## Installation

The ball valves may be installed in any position using standard pipe fitting practice. It is recommended that unions be installed before each end of threaded and welded multiport valves for easy installation and removal.

### CAUTION: Before installation of the valve:

1. Pipe must be free of tension both during and after installation.
2. Pipe must be flushed to clean dirt, welding residues, etc. which would damage ball or seats.
3. The valve should be kept in OPEN POSITION during installation and protective plastic covers must be removed only at the moment of installation.
4. Before shipment, the ball is lubricated with a pure Vaseline oil. This can be easily removed with an application compatible solvent if required.
5. If the valve was specified to be tested per ANSI B16.34, there may be some trapped water between the ball and the body cavity. This can be removed by partially opening the valve, thereby exposing the cavity to the through port of the ball.
6. Special care should always be taken when installing automated ball valves that the ball is in the proper position.

### Installation of Threaded End Ball Valves

1. Unless otherwise specified, pipe threads are American National Standard Taper Pipe Threads (NPT) per ANSI B1.20.1, and require that a pipe sealant be used.
2. Use an anti-seize thread sealant to seal and prevent galling.
  - a. Marwin recommends PTFE-based liquid sealant or Grafoil tape as thread sealants.
  - b. Notes:
    1. Use all pipe sealant products in accordance with the manufacturer's instructions and good piping practices.
    2. Correct lubrication of stainless steel pipe threads is especially important to prevent galling.
3. To prevent distortion or damage to the valve, do not apply torque through the valve. When tightening valve, use wrench on the end nearest the pipe being tightened.
4. Always leak test the system before using.

### Installation of Welded-End Ball Valves

1. Because the valve cannot be disassembled without removing it from the line or spreading the pipe, socket and butt weld end valves are normally furnished with extended ends to allow welding without disassembly.
2. Extended end valves may be welded into place without disassembly using the following guidelines:
  - Valve must be in the full open position.
  - Tack weld in four points on both end caps.
  - Limit continuous weld time to 1 minute.
  - Direct moving air across finned area or wrap extended end with wet cloth.
  - Check body bolts for proper torque after welds have completely cooled per assembly section of this procedure.

**NOTE: Guide for extended valve installations does not apply to UHMW-PE or Delrin® seats or standard EPDM or Nitrile body seals due to the low tolerance to high temperatures of these materials.**

### Installation of Flanged-End Ball Valves

1. Verify valve is in the full open position.
2. Use the appropriate size bolt and heavy hex nut (not in-

cluded) as recommended for flange size and class.

3. Flange connection requires gasket (not included).
4. Follow gasket manufacturer's recommended practice for tightening flange bolts.

## Manual Operation

Reposition the valve by turning the handle one-quarter turn (90°). The top of the stem shows the open ports. The handle can be oriented in 90° increments. Care must be taken to ensure valve open ports are oriented as needed.

## Port Configuration

### Three-Way "T" Port 180°

Three-Way "T" Port 180°			
Position Flow Pattern	A* (0°)	B (90°)	C (180°)
T1 180°			
T2 180°			
T6 180°			
T7 180°			

### Three-Way "T" Port 90°

Three-Way "T" Port 90°			
Position Flow Pattern	A* (0°)	B (90°)	C (180°)
T3 90°			
T4 90°			
T8 90°			
T9 90°			

### Three-Way "L" Port 180°

Three-Way "L" Port 180°			
Position Flow Pattern	A* (0°)	B (90°)	C (180°)
L1 180°			
L3 180°			
L4 180°			
L6 180°			

### ■ Three-Way "L" Port 90°

Three-Way "L" Port 90°			
Position Flow Pattern	A* (0°)	B (90°)	C (180°)
L2 90°			
L5 90°			

### ■ Four-Way "L" Port

Four-Way "L" Port			
Position Flow Pattern	A* (0°)	B (90°)	C (180°)
L20 180°			

### ■ Four-Way "LL" Port

Four-Way "LL" Port			
Position Flow Pattern	A* (0°)	B (90°)	C (180°)
LL30 90°			

## Maintenance

Before starting maintenance, please read information contained in the **Caution Section** of the manual.

1. Operate the ball valve at least once to completely release the pressure from valve body.
2. Ball valves, if correctly used, normally do not need any internal lubrication and maintenance. However, when necessary, ball or seats can be replaced by qualified personnel following the instructions of this manual.
3. For further information, please refer to **SPARE PARTS LIST Section**.

## Valve Disassembly

1. Always depressurize the pipeline with the valve in the open position and cycle valve to remove media that might be trapped inside valve cavity before disassembling valve or removing it from pipeline.
2. Remove valve from pipeline.
3. To facilitate reassembly of the valve so that the operation is not changed, it is recommended that the orientation of the following be marked: stopper (not shown), stem (using port markings on top of stem as reference), top cover (using stop bolt (not shown) as reference), and ball ports. In addition, each cap and cover should be match marked to the body so that everything is reassembled in the same location and orientation.
4. Remove handle (26), handle adapter (25), handle nut (1), lock washer (2), stopper (3), and Belleville washers (4).

5. Unbolt and remove all the end caps (17), back cap (24), and top cover (14).
6. Lift ball (12) out top of body (20), being careful not to damage ball.
7. Push stem (11) through top cover (14). Be careful to remove or secure anti-static ball and spring so that they are not lost from stem.
8. Remove packing gland (5), packing thrust washer (6), and packing (7), from packing chamber in top cover.
9. Remove stem seal parts (10) from stem shoulder recess in top cover.
10. Remove top cover seal (15) and end cap seals (22).
11. Remove seats (23) from end caps (17) and back cap (24).
12. Remove ball support bearing (21) from body (20).

**NOTE: A spare parts kit is available for this valve. Refer to exploded view for identification. Please specify specific valve number to ensure proper parts are ordered. Marwin Valve does not take responsibility for incorrectly ordered spare parts.**

Spare Parts Kit		
Item #	Quantity	Part Name
7	1	V-Ring Stem Packing
22	4	Gasket, End Cap
23	4	Seat
15	1	Gasket, Top Cover
21	1	Ball Support Bearing
10A	1	Lower Thrust Washer
10B	1	Compression Ring
10C	1	Upper Thrust Washer

### ■ Inspection and Replacement

Clean and inspect all components to be sure that they are free from foreign matter and pit marks, paying particular attention to the areas that must maintain a seal.

1. Ball. The surface of the ball should be free from any defect. If any are found, the ball should be replaced. Using a defective ball will be extremely detrimental to valve performance.
2. Seats. Replacement of seats is recommended.
3. Stem Seals and Body Seals. Stem and body seals should be discarded and replaced.
4. Remaining Components of the Valves. After cleaning, carefully examine for wear, corrosion, and mechanical damage. Pay particular attention to finished diameter on stem, stem seal areas on top cover, and gasket sealing surfaces on body, caps and cover. Replace all defective parts.

## Re-Assembly

Reassemble valve, using the recommended factory repair kit.

1. Place new stem seals (10) on stem (11), and insert through top cover (14). Install packing (7), packing thrust washer (6), packing gland (5), Belleville washers (4), stop plate (3), lock washer (2), and stem nut (1). Adjust stem packing to feel snug and firm (refer to stem nut torque in Torque Table).
2. Replace ball support bearing (21) in body (20).

- Place ball (12) into body (20) cavity. Insure that ball ports are in proper orientation to body.
- Insert seats (23) and seals (22) into caps (17) and (24), and seals (15) into top cover (14).
- Mount caps (17) and (24) and top cover (14) on body (20) in proper orientation, and secure with bolts or studs and nuts (19), (18), (16) and (13). Tighten nuts to torques shown in Torque Table. Tighten in small increments in a diagonal pattern, and alternate between covers to compress seats evenly. Uneven force applied to the caps could cause seat compression to be too tight or too loose, affecting valve performance.

## Testing

- After completing the reassembly, check that the valve operates smoothly by opening and closing valve several times.
- If entire valve was removed from line and if facilities are available, test the ball valve to appropriate specifications.

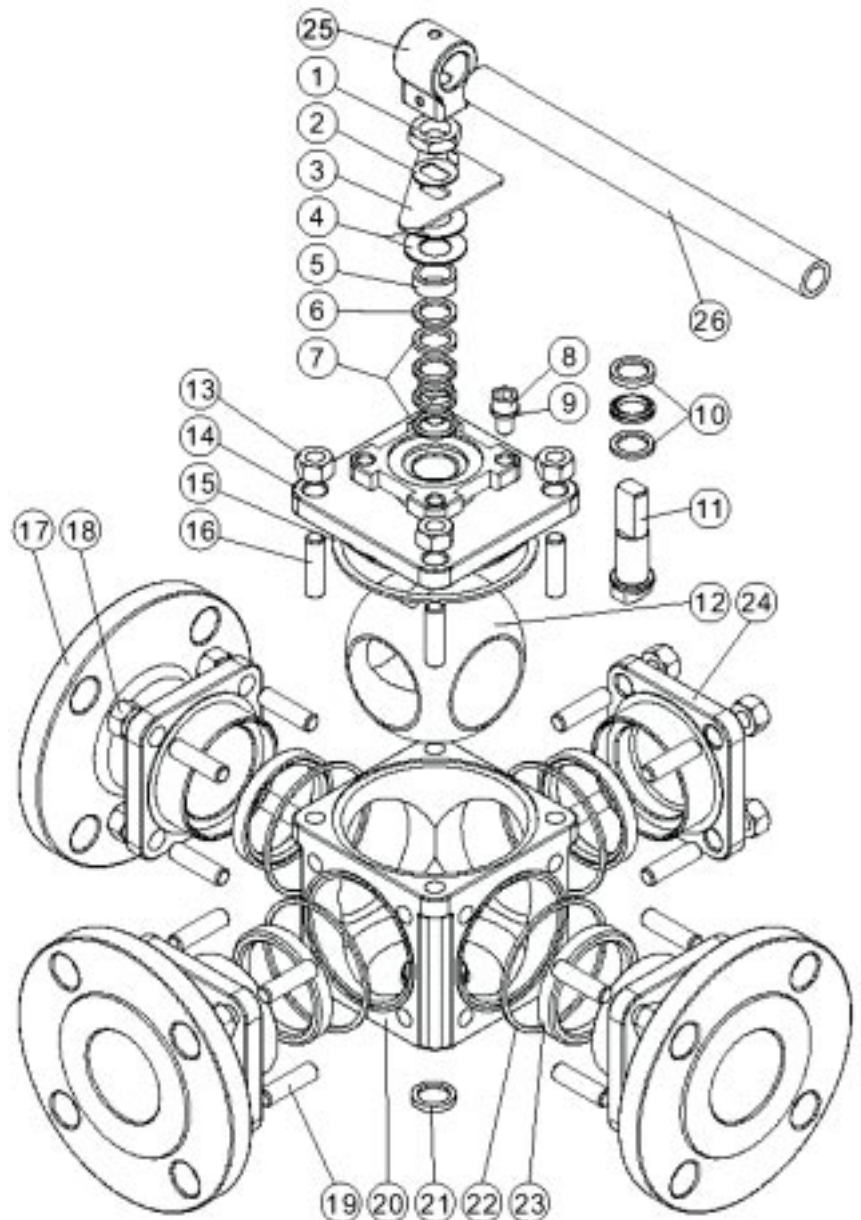
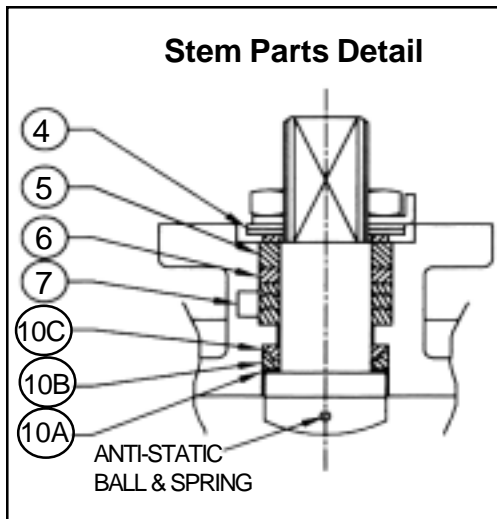

## Troubleshooting

### A. Stem Leakage

- Leakage in the stem packing area may be eliminated by increasing the torque on the stem nut (1) in one-quarter turn increments. If leakage persists, replace stem seal parts (10) and packing (7).

### B. Body Seal Leakage

- Check the torque of the cap and cover bolts or nuts (18) and (13) according to Torque Table. Replace cap gasket (22) and cover gasket (15) if leakage persists.

### C. In Line or Seats Leakage

- Check to be sure valve is in fully closed position. If leakage persists, the valve must be disassembled and damaged parts replaced.

**Material Specifications — 3L/T-2S33 3-Way/4-Way Class 150/300 Ball Valve**

Item No.	Quantity	Part Name
1	1	Stem Nut
2	1	Lock washer
3	1	Stop Plate, Handle
4	2	Bellville Washer
5	1	Packing Gland
6	1	Packing Thrust Washer
7	1	V-Ring Stem Packing
8	1	Stop Bolt
9	1	Spring Washer
10	1	Stem Seal Parts
11	1	Stem, Anti-Static
12	1	Ball
13	1	Nut, Top Cover
14	1	Cover, Top
15	1	Seal, Top Cover
16	1	Stud, Top Cover
17	3	End Cap, Flanged
18	20	Nut, End Cap
19	20	Stud, End Cap
20	1	Body
21	1	Bearing, Ball Support
22	4	Seal, End Cap
23	4	Seat
24	1	Back Cover
25	1	Handle Adaptor
26	1	Handle

**BODY BOLT TORQUE VALUE TABLE**

Valve Size (in)	Body Bolt		Top Cover Bolt		Stem Nut Torque (in-lb)
	Bolt Size	Torque (in-lb)	Bolt Size	Cover Bolt Torque (in-lb)	
2"	M10	345	M10	345	130-150
2-1/2"	M12	580	M12	580	190-210
3"	M12	580	M12	580	190-210
4"	M12	580	M12	580	290-310
6"	M16	1450	M16	1450	500-550

Note: Torque figures are based on full port valve. Use one size smaller for reduced port valves.



3170 Wasson Road • Cincinnati, OH 45209 USA  
 Phone 513-533-7340 • Fax 513-533-7343  
 Phone Toll-Free: 800-628-2583 (USA)  
 E-Mail: [marwin@richardsind.com](mailto:marwin@richardsind.com)  
[www.marwinvalve.com](http://www.marwinvalve.com)