

28-68801

TOP MOUNTING DIMENSIONS FOR MODEL NO. 1/2"-10" 6800R-A

NO	DESCRIPTION	DATE	BY
A	MEC 06045	7/31/06	DW

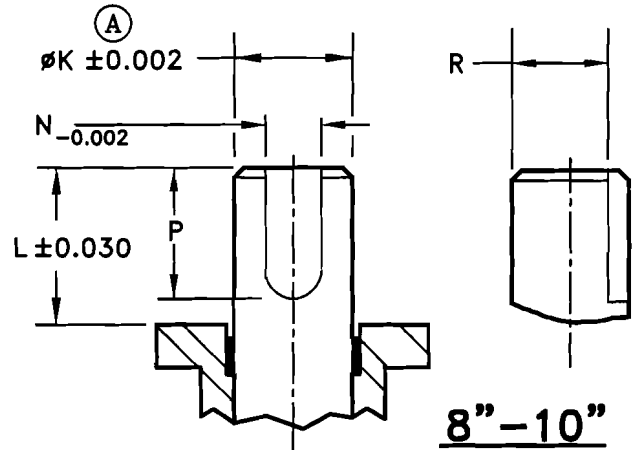
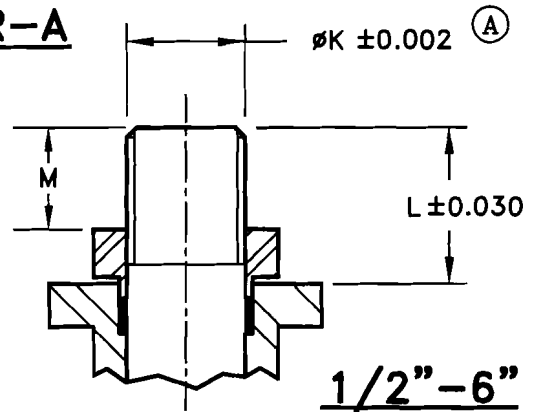
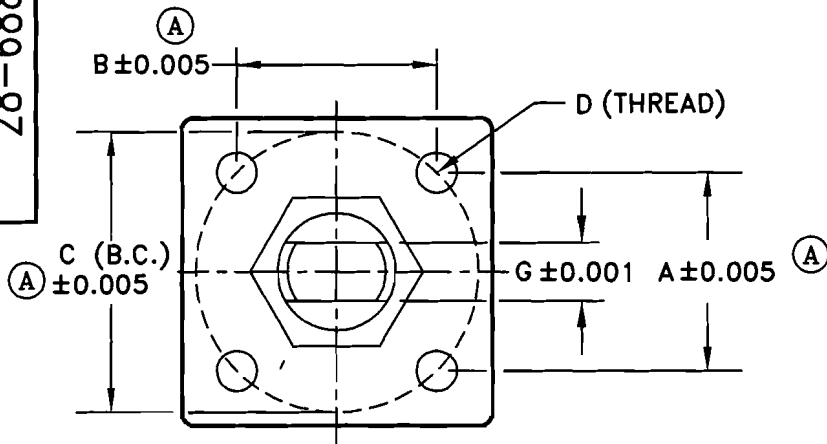

- A, B & C (B.C.) = MOUNTING PAD SPACING
- D = THREAD OF MOUNTING HOLES
- G = ACROSS FLAT ON STEM
- K = STEM DIAMETER (THREAD)
- L = DISTANCE TO TOP OF STEM FROM MOUNTING PAD
- M = DISTANCE TO TOP OF STEM FROM TOP OF NUT
- N = KEYWAY WIDTH
- P = KEYWAY HEIGHT
- R = KEYWAY DEPTH

VALVE SIZE	DIMENSIONS (INCHES)											
	A	B	C (B.C.)	D (THRD)	MTG PTRN	G	øK	L	M	N	P	R
1/2"	1.002	1.002	ø1.42	10-24	F03	0.160	M8X1.25	0.39	0.26	-	-	-
3/4"	1.392	1.392	ø1.97	1/4-20	F05	0.310	M12X1.25	0.41	0.35	-	-	-
1"	1.392	1.392	ø1.97	1/4-20	F05	0.310	M12X1.25	0.54	0.35	-	-	-
1 1/2"	1.392	1.392	ø1.97	1/4-20	F05	0.390	M16X1.5	0.79	0.51	-	-	-
2"	1.392	1.392	ø1.97	1/4-20	F05	0.390	M16X1.5	1.15	0.76	-	-	-
2 1/2"	1.949	1.949	ø2.76	5/16-18	F07	0.550	M20X1.5	1.29	0.90	-	-	-
3"	1.949	1.949	ø2.76	5/16-18	F07	0.550	M20X1.5	1.15	0.90	-	-	-
4"	2.840	2.840	ø4.02	3/8-16	F10	0.790	M28X1.5	1.58	1.09	-	-	-
6" (SP)	2.840	2.840	ø4.02	3/8-16	F10	0.790	M28X1.5	1.56	1.09	-	-	-
8" (SP)	3.897	3.897	ø5.51	5/8-11	F14	-	ø1.65	2.16	-	0.472	2.09	1.44
10" (SP)	3.897	3.897	ø5.51	5/8-11	F14	-	ø1.65	2.17	-	0.472	2.09	1.44



RICHARDS INDUSTRIES
3170 Wasson Rd.
Cincinnati, Ohio 45209
Telephone (513) 533-5600
Fax (513) 533-7343

DR. BY	DW	03/21/05
CHK. BY		

28-68801