

28-68800

TOP MOUNTING DIMENSIONS FOR MODEL NO. 1/2"-8" 6800F-A

NO	DESCRIPTION	DATE	BY
A	MEC 06045	7/31/06	DW

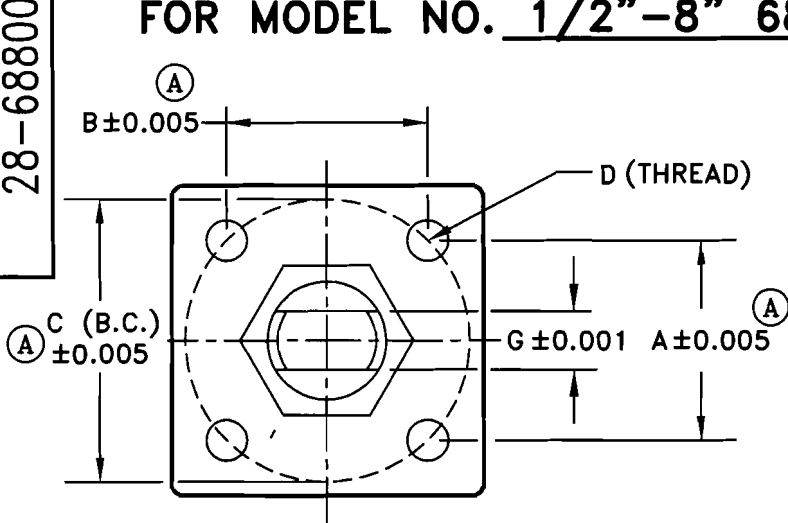

- A, B & C (B.C.) = MOUNTING PAD SPACING
- D = THREAD OF MOUNTING HOLES
- G = ACROSS FLAT ON STEM
- K = STEM DIAMETER (THREAD)
- L = DISTANCE TO TOP OF STEM FROM MOUNTING PAD
- M = DISTANCE TO TOP OF STEM FROM TOP OF NUT
- N = KEYWAY WIDTH
- P = KEYWAY HEIGHT
- R = KEYWAY DEPTH

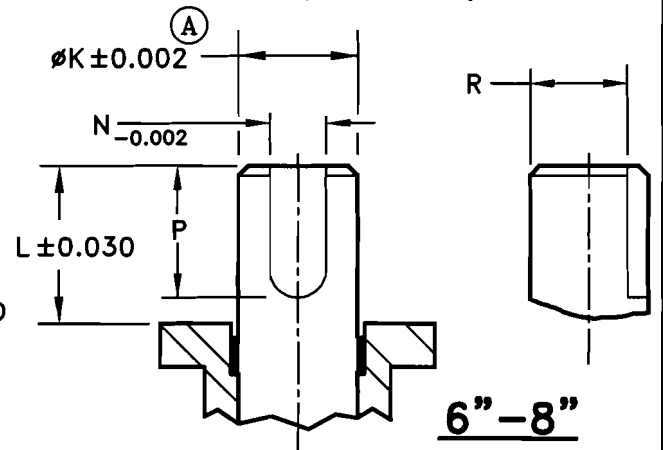
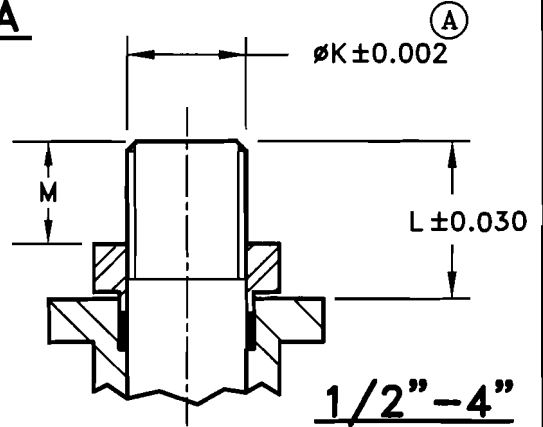

VALVE SIZE	DIMENSIONS (INCHES)											
	A	B	C (B.C.)	D (THRD)	MTG PTRN	G	ØK	L	M	N	P	R
1/2"	1.392	1.392	Ø1.97	1/4-20	F05	0.310	M12x1.25	0.49	0.35	-	-	-
3/4"	1.392	1.392	Ø1.97	1/4-20	F05	0.310	M12x1.25	0.54	0.35	-	-	-
1"	1.392	1.392	Ø1.97	1/4-20	F05	0.390	M16x1.5	0.73	0.46	-	-	-
1 1/2"	1.392	1.392	Ø1.97	1/4-20	F05	0.390	M16x1.5	1.15	0.76	-	-	-
2"	1.949	1.949	Ø2.76	5/16-18	F07	0.550	M20x1.5	1.29	0.90	-	-	-
2 1/2"	1.949	1.949	Ø2.76	5/16-18	F07	0.550	M20x1.5	1.21	0.90	-	-	-
3"	2.840	2.840	Ø4.02	3/8-16	F10	0.790	M28x1.5	1.58	1.09	-	-	-
4"	2.840	2.840	Ø4.02	3/8-16	F10	0.790	M28x1.5	1.56	1.09	-	-	-
6"	3.897	3.897	Ø5.51	5/8-11	F14	-	Ø1.65	2.16	-	0.472	2.09	1.44
8"	3.897	3.897	Ø5.51	5/8-11	F14	-	Ø1.65	2.17	-	0.472	2.09	1.44

MARWIN

Ball Valves

RICHARDS INDUSTRIES
3170 Wasson Rd.
Cincinnati, Ohio 45209
Telephone (513) 533-5600
Fax (513) 533-7343

DR. BY	DW	03/21/05	28-68800
CHK. BY			