

28-58803

# TOP MOUNTING DIMENSIONS FOR MODEL NO. 5801R

NO	DESCRIPTION	DATE	BY

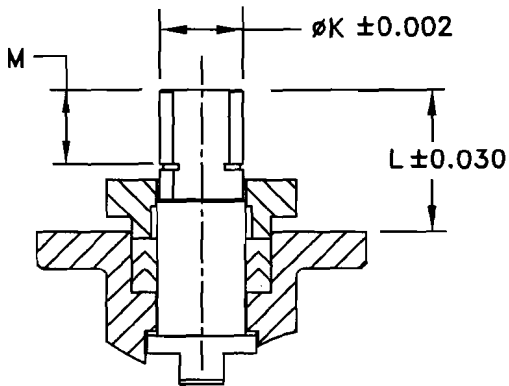
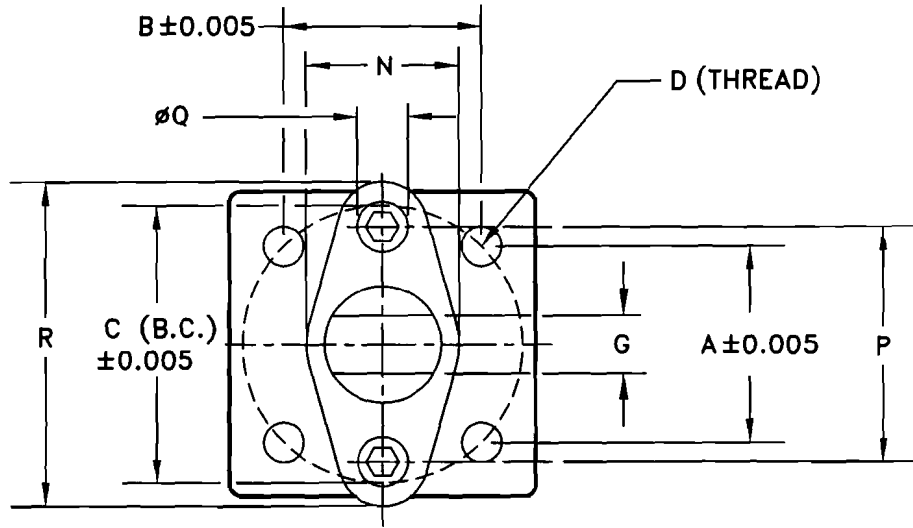

- A, B & C (B.C.) = MOUNTING PAD SPACING
- D = THREAD OF MOUNTING HOLES
- G = ACROSS FLAT ON STEM
- K = STEM DIAMETER
- L = DISTANCE TO TOP OF STEM FROM MOUNTING PAD
- M = DISTANCE TO TOP OF STEM FROM TOP OF SNAP RING
- N = GLAND WIDTH
- P = GLAND B.C.
- R = GLAND LENGTH
- Q = GLAND BOLT HEAD DIA

VALVE SIZE	DIMENSIONS (INCHES)												
	A	B	C (B.C.)	D (THRD)	MTG	G	øK	L	M	N	P	R	øQ
1"	1.392	1.392	ø1.97	M6X1	F05	0.315/0.313	0.47	0.76	0.30	1.10	1.50	2.00	0.39
1 1/2"	1.392	1.392	ø1.97	M6X1	F05	0.394/0.392	0.59	1.07	0.52	1.35	1.84	2.44	0.47
2"	1.949	1.949	ø2.76	M8X1.25	F07	0.551/0.549	0.75	1.31	0.70	1.71	2.22	2.97	0.55
3"	2.840	2.840	ø4.02	M10X1.5	F10	0.630/0.628	0.95	1.75	0.96	2.09	2.83	3.75	0.55
4"	2.840	2.840	ø4.02	M10X1.5	F10	0.630/0.628	0.95	1.75	0.96	2.09	2.83	3.75	0.71
6"	2.840	2.840	ø4.02	M10X1.5	F10	0.787/0.785	1.18	1.86	0.96	2.31	3.08	4.33	0.95
8"	3.480	3.480	ø4.92	M12X1.75	F12	1.024/1.022	1.50	2.48	1.28	2.82	3.94	5.08	0.95

**MARWIN**  
Ball Valves

RICHARDS INDUSTRIES  
3170 Wasson Rd.  
Cincinnati, Ohio 45209  
Telephone (513) 533-5600  
Fax (513) 533-7343

DR. BY	DW	03/01/07
CHK. BY		

28-58803