

28-58802

TOP MOUNTING DIMENSIONS FOR MODEL NO. 5801F

| NO | DESCRIPTION | DATE | BY |
|----|-------------|------|----|
| | | | |

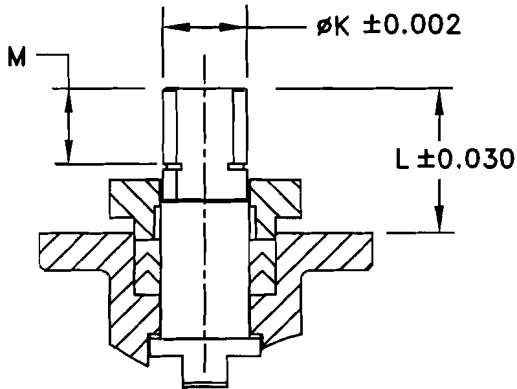
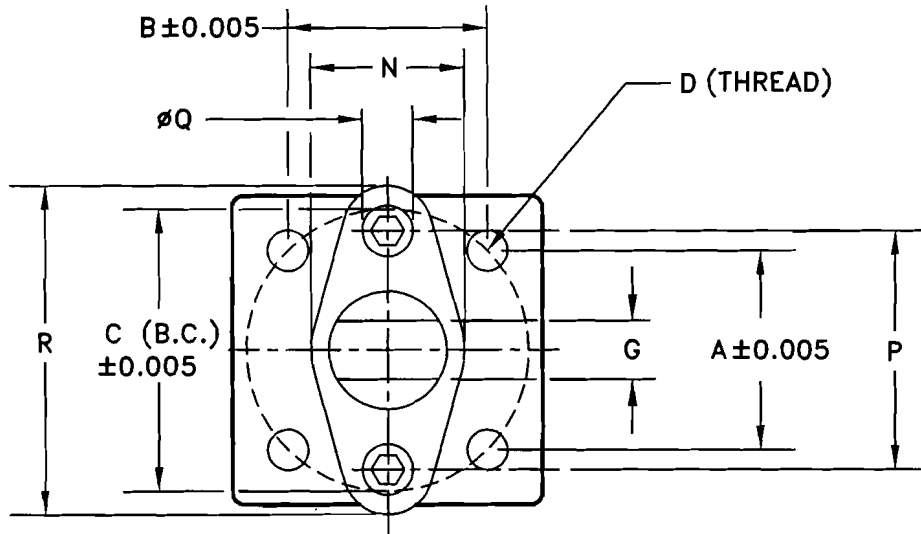

- A, B & C (B.C.) = MOUNTING PAD SPACING
- D = THREAD OF MOUNTING HOLES
- G = ACROSS FLAT ON STEM
- K = STEM DIAMETER
- L = DISTANCE TO TOP OF STEM FROM MOUNTING PAD
- M = DISTANCE TO TOP OF STEM FROM TOP OF SNAP RING
- N = GLAND WIDTH
- P = GLAND B.C.
- R = GLAND LENGTH
- Q = GLAND BOLT HEAD DIA

| VALVE SIZE | DIMENSIONS (INCHES) | | | | | | | | | | | | |
|------------|---------------------|-------|----------|----------|-----|-------------|------|------|------|------|------|------|------|
| | A | B | C (B.C.) | D (THRD) | MTG | G | øK | L | M | N | P | R | øQ |
| 1/2" | 1.392 | 1.392 | ø1.97 | M6X1 | F05 | 0.315/0.313 | 0.47 | 0.64 | 0.19 | 1.10 | 1.50 | 2.00 | 0.39 |
| 3/4" | 1.392 | 1.392 | ø1.97 | M6X1 | F05 | 0.315/0.313 | 0.47 | 0.76 | 0.30 | 1.10 | 1.50 | 2.00 | 0.39 |
| 1" | 1.949 | 1.949 | ø2.76 | M8X1.25 | F07 | 0.394/0.392 | 0.59 | 1.07 | 0.52 | 1.35 | 1.84 | 2.44 | 0.47 |
| 1 1/2" | 1.949 | 1.949 | ø2.76 | M8X1.25 | F07 | 0.551/0.549 | 0.75 | 1.29 | 0.68 | 1.35 | 2.22 | 2.82 | 0.47 |
| 2" | 1.949 | 1.949 | ø2.76 | M8X1.25 | F07 | 0.551/0.549 | 0.75 | 1.29 | 0.68 | 1.71 | 2.22 | 2.97 | 0.55 |
| 2 1/2" | 1.949 | 1.949 | ø2.76 | M8X1.25 | F07 | 0.551/0.549 | 0.75 | 1.29 | 0.68 | 1.71 | 2.22 | 3.14 | 0.55 |
| 3" | 2.840 | 2.840 | ø4.02 | M10X1.5 | F10 | 0.630/0.628 | 0.95 | 1.75 | 0.96 | 2.09 | 2.83 | 3.75 | 0.71 |
| 4" | 2.840 | 2.840 | ø4.02 | M10X1.5 | F10 | 0.787/0.785 | 1.18 | 1.81 | 0.96 | 2.31 | 3.08 | 4.33 | 0.95 |
| 6" | 3.480 | 3.480 | ø4.92 | M12X1.75 | F12 | 1.024/1.022 | 1.50 | 2.48 | 1.28 | 2.82 | 3.94 | 5.08 | 0.95 |
| 8" | 3.897 | 3.897 | ø5.51 | M16X2 | F14 | 1.260/1.258 | 1.89 | 3.01 | 1.66 | 3.35 | 4.72 | 5.95 | 0.95 |



MARWIN

Ball Valves

RICHARDS INDUSTRIES
3170 Wasson Rd.
Cincinnati, Ohio 45209
Telephone (513) 533-5600
Fax (513) 533-7343

| | | | |
|---------|----|----------|----------|
| DR. BY | DW | 01/31/07 | 28-58802 |
| CHK. BY | | | |